

User's Manual

N O C P I X

# MATE SERIES

Multifunction Thermal Clip-On



 **Nocpix**

## WARNING! ITAR REQUIREMENTS

These products may be subject to export and foreign trade control laws of the United States and may not be exported without prior approval of the U.S. Department of State. Learn more at [irayusa.com/ITAR](http://irayusa.com/ITAR).

### CAUTION

Use of controls or adjustments or performance of procedures other than those specified herein may result in hazardous radiation exposure.

2601 State Hwy 121, Building 3, Suite 306, Lewisville, TX 75056  
800.769.7125 [info@irayusa.com](mailto:info@irayusa.com)

NOTICE: This product is a Class 3R laser product.

#### Mfr ID and Certification Label



#### Explanatory Label

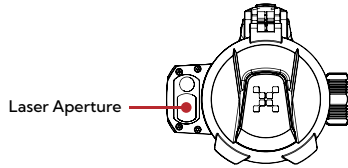
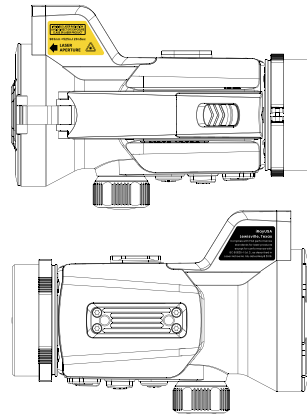

**NOTE:** There is no scheduled maintenance or service necessary to keep this product in compliance and no user service or maintenance is required.

This Laser Product is designated as Class 3R during all procedures of operation.

Wavelength: 903 nm  
Laser Power for Classification: <525 nJ  
Emission Type: Pulsed, Invisible  
Pulse Width: 20 nSec

#### NOTES:

- There is no service required or allowed of this product by the end user.
- This product is to be serviced or repaired only by factory authorized technicians.
- This product is not to be opened or modified by the user.
- The user is not to modify the unit or remove protective covers or housing. Service is only to be handled by authorized factory trained technicians. This product has no user-serviceable parts.
- Do not point laser or allow laser light to be directed or reflected toward other people or reflective objects.
- Operators should be trained to not target the eyes of people, animals, and pets or aim at reflective objects, etc.
- This laser is never to be operated if the unit is defective or the cover or seal is damaged.
- Always operate the product with the aperture pointed downrange.

## Table of Contents

1.	Overview .....	2
2.	Features .....	2
3.	Tech Specs .....	3
4.	Accessories .....	4
5.	Components and Controls .....	5
6.	Description of Control Buttons and Shortcuts .....	6
7.	Quick Start Guide .....	7
8.	Powering and Charging the MATE Series .....	9
9.	Mounting the MATE Series .....	13
10.	Operating Instructions .....	15
11.	Non-Uniformity Correction .....	20
12.	Photography and Video Recording .....	21
13.	Accessing the Internal Memory .....	22
14.	Using the NOCPIX App .....	23
15.	Remote Control .....	24
16.	Integrated Laser Rangefinder .....	25
17.	Magic Zoom .....	27
18.	Quick Menu Options and Descriptions .....	30
19.	Main Menu Options and Descriptions .....	34
20.	Basic Inspection .....	58
21.	Basic Maintenance .....	59
22.	Warranty .....	59
23.	FCC Statement .....	60
24.	General Troubleshooting .....	61
25.	Notes .....	62

### WARNING: CHOKING HAZARD

Children under 3 years old can choke or suffocate on small parts of this product. This product is not a toy; keep out of reach of children.

## 1. Overview

New for 2026, the Nocpix MATE ULTRA combines the world's best production 1280x1024 thermal sensor and an integrated 1,300-yard capable laser rangefinder with the compact versatility of a thermal clip-on. Compatible with magnifications up to 12x, the MATE ULTRA can be mounted in front of your existing day optic to gain full thermal detection without the need to re-zero or swap optics. The MATE features an adjustable heads-up display for a clear, full-detail sight picture at any magnification, multiple zeroing profiles for consistent point-of-impact retention across multiple rifles, and runs on standard 18650 rechargeable batteries. Whether you're hunting hogs, controlling predators, or running multiple rifle setups, the MATE series is built to perform when the sun goes down.

## 2. Features

- Reality+ technology
- ≤15 mK sensor sensitivity
- 12 μm high-performance thermal detector
- Integrated 1,300 yd laser rangefinder
- Magic Zoom with smart AI scaling
- Magnesium alloy housing
- Maximum detection range: 3,390 yards
- 1920x1200 AMOLED display
- High frame frequency: 60Hz
- Recoil-activated video with slow-motion shot capture
- Includes four replaceable IRB-2 18650-style batteries
- User-defined, multi-variable ballistics calculator
- Multiple zero profiles and ranges
- Built-in 64 GB storage to support image capture and video recording
- Built-in Wi-Fi module
- Mobile device App compatible
- Pixel calibration function
- Ultra-Clear mode for advanced image detail
- Multiple color palettes
- Warm and cool image-hue options
- Compact and lightweight
- User-friendly interface

## 3. Tech Specs

MATE SERIES	ULTRA S60R
<b>Sensor</b>	
Resolution	1280x1024
Pixel Size	12 μm
Frame Rate	60hz
Sensor Sensitivity	≤15 mK
Image Processing	Reality+
Core	Nocpix 1280
<b>Optics</b>	
Objective Lens	60 mm f/1.0
Magnification	1x
Digital Zoom	Magic Zoom (Auto Scaling)
Field of View	14.7° × 11.7°
Detection Range	3390 Yards
Display Type	AMOLED
Display Resolution	1920x1200
Color Palettes	White Hot, Black Hot, Red Hot, Rainbow, Viridian, Crimson, Violet
P.I.P.	None
Rangefinder	Integrated 1,300 yd LRF
Eye Relief	20 mm
<b>Electronics</b>	
Onboard Recording	Video, Recoil-Activated Video, and Image
Onboard Storage	64 GB
Wireless Connectivity	Image and Video via App.
Data/Power Connector	USB-C
Power Supply	USB-C External, 18650 Batteries x4 (4+ Hrs Ea)
Start Up Time	<10 Seconds, Instant from Standby
<b>Physical</b>	
Size	5.51" × 3.78" × 3.07"
Weight	19.75 Oz
<b>Environmental/Warranty</b>	
Warranty	5 Years
Housing Material	Magnesium Alloy
Ingress Protection	IP67
Operation Temperature	-4°F--122°F
Max. Recoil	1000 g/s <sup>2</sup> (300 Win./7mm Mag)

## 4. Accessories

The MATE Series Multifunction Thermal Clip-On ships with everything you need to get out and hunt.

- IRB-2 18650 Batteries ×4
- IRB-2 18650 Battery Charger
- Universal Scope Adapter and Adapter Inserts
- USB-C Cable
- Remote Control with Base and Velcro Strap
- Magic Zoom with Straps
- Magic Zoom Batteries ×2
- Battery Charger/Case for Magic Zoom and Remote
- Soft Carry Bag
- Lens Cloth
- User Manual



Various replacement accessories are available for purchase. Contact us at 800-769-7125 or [irayusa.com/support](http://irayusa.com/support).

## 5. Components and Controls

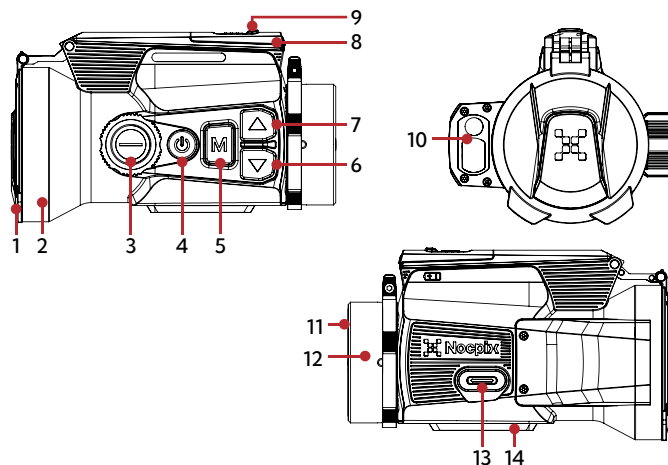



- 1 Objective Lens Cap
- 2 Objective Lens
- 3 Objective Lens Focus Knob
- 4 Power Button
- 5 Menu Button
- 6 Down Button
- 7 Up Button
- 8 Battery Compartment
- 9 Battery Cover Release Latch
- 10 Laser Rangefinder
- 11 Eyepiece
- 12 M52×0.75 Threaded Ring for Universal Adapter
- 13 USB-C Cover / Port
- 14 Mounting Interface for IRAY AC-03 Mount (not included)

## 6. Description of Control Buttons and Shortcuts

Power Button 		
Current Screen, Menu, or Device Status	Short Press	Long Press
Device off	---	Power on the device.
Home screen	Manually perform a non-uniformity correction.	<b>Long Press to open the shutdown screen:</b> <ul style="list-style-type: none"> <li>Release the Power button to enter standby mode.</li> <li>Hold through the 3-second countdown to shutdown.</li> </ul>
Main menu / quick menu	Return to home or previous menu without saving changes.	
Continuous ranging	Stop continuous ranging.	
Standby mode	Exit standby mode.	---
Defect pixel correction, zeroing, and ref. line calibration interfaces	Exit the interface without saving.	---

Up Button 		
Current Screen / Menu	Short Press	Long Press
Home screen	Take a single ranging measurement.	<b>Continuous LRF is ON:</b> Start continuous ranging.
		<b>Continuous LRF is OFF:</b> Long press, move LRF cursor to target, then release the button to take a single ranging measurement.
Main menu / quick menu	Move the cursor up.	---
Defect pixel correction, zeroing, and ref. line calibration interfaces	Move the cursor 1 pixel in the positive direction.	Move the cursor 10 pixels in the positive direction.

Down Button 		
Current Screen / Menu	Short Press	Long Press
Home screen	<b>Short Press:</b> Toggle through the UI zoom levels	Start / stop recording video.
	<b>Double-Click:</b> Take a photo.	
Main menu & quick menu	Move the cursor down.	---
Defect pixel correction, zeroing, and ref. line calibration interfaces	Move the cursor 1 pixel in the negative direction.	Move the cursor 10 pixels in the negative direction.

Menu Button 		
Current Screen / Menu	Short Press	Long Press
Home screen	Enter the quick menu.	Enter the main menu.
Main menu	Change menu parameters; enter submenu; or confirm submenu changes and return to previous menu.	Confirm selection or changes and return to the home screen.
Quick menu	Toggle through the quick menu parameters.	Exit the quick menu.
Defect pixel correction, zeroing, and ref. line calibration interfaces	Select / deselect the axis of movement (X or Y).	Save changes and return to previous.

## 7. Quick Start Guide

### Step 1: Prepare to Use the MATE Series

1. Compare the box contents to the accessories list and examine each for any shipping damage. See **Accessories** on page 4.
2. Check the lens to ensure there are no smudges or dirt present. Clean with the included lens cloth, if necessary.
3. Charge the batteries. See **Powering and Charging the MATE Series** on page 9.

### Step 2: Turn On the MATE Series

1. Open the objective lens cap.
2. Long press the **Power**  button for 2 seconds to power on the MATE Series.

**WARNING:** Do not point the objective lens toward intense energy sources, such as the sun. This may render the electronic components inoperative. The warranty does not cover damage caused by improper operation.

### Step 3: Adjust Quick-Menu Settings

Short press the **Menu**  button to enter the quick menu to adjust the following settings (see **Quick Menu Options and Descriptions** on page 30):

1. Set the color palette to white hot, black hot, red hot, rainbow, violet, crimson, or viridian.
2. Select a screen brightness level, from 1 to 6.
3. Select an image contrast level, from 1 to 6.
4. Select an image sharpness level, from 1 to 6.
5. Turn Ultra-Clear mode on.
6. Set the image hue mode to warm or cool.
7. When ballistic calculation is enabled, select a preset ballistic calculation distance or add/edit a quick distance.

### Step 4: Adjust Main-Menu Settings

Long press the **Menu**  button to enter the main menu (see **Main Menu Options and Descriptions** on page 34 for detailed instructions) to adjust the following settings:

1. Turn on Wi-Fi to control the MATE Series via the NOCPiX App.
2. Turn on N-Link to connect two NOCPiX devices.
3. Turn on recoil-activated video, and set the recoil sensitivity.
4. Turn on the microphone.
5. Set the non-uniformity correction (NUC) mode to automatic, manual, or background.
6. Turn on the motion sensor.
7. Set the date and time.
8. Set the units to meters or yards.

### Step 5: Install Accessories (Optional)

1. Install and calibrate the Magic Zoom:
  - a. Install the Magic Zoom battery. When properly installed, the battery icon on the side of the battery is on the same side as the Power button.
  - b. Use one of the included straps to attach the Magic Zoom to the magnification adjustment ring of the day scope.
  - c. Calibrate the Magic Zoom.
  - d. See page 27 for detailed installation, charging, and calibration instructions.
2. Connect the remote; see instructions on page 24.

### Step 6: Zero the MATE Series (Optional)

When using the MATE Series mounted to a day scope.

1. In the main menu, set the eyepiece mode to clip-on. See **Main Menu > Eyepiece** on page 54.
2. Mount the MATE Series to a day scope. See mounting instructions on page 13.
3. Create a zeroing profile and customize the settings. See **Main Menu > Zeroing** on page 36.

## 8. Powering and Charging the MATE Series

The MATE Series comes with 4 replaceable 18650 batteries. Each battery provides up to 4 hours of run time, depending on device settings and environmental conditions.

When the battery status icon in the device status bar turns red, charge the battery promptly to prevent over-discharge, which can reduce battery capacity and service life. Please ensure batteries are fully charged before use.

### Charging and Powering Via USB-C

When connected to an external power source via USB-C, the 18650 battery will charge automatically. The MATE Series supports a 5V external power supply, such as a mobile power bank.

To charge or power the MATE Series via USB-C:

1. Connect the USB-C cable (15) to the USB-C port (13) on the MATE Series.
2. Connect the USB end of the cable to an external power source:
  - a. Any standard USB port on a laptop or computer; OR
  - b. A 5V-2A USB power adapter (plug the power adapter into an electrical outlet); OR
  - c. 5V external power supply, such as a mobile power bank.
3. The MATE Series switches to external power and begins charging the 18650 battery:
  - a. The LED status indicator next to the USB-C port (13) is red during charging.
  - b. The battery status icon in the status bar changes to a charging battery  icon.
4. When charging is complete, disconnect the USB-C cable. Do not overcharge.

- When the external power source is disconnected, the MATE Series automatically switches to the 18650 battery without powering off.

**WARNING:** Never charge the battery with a USB adapter that is greater than 5V–2A.

**NOTE:** Do not connect to any external device with a current supply that exceeds the USB 3.0 (5 V) specifications.

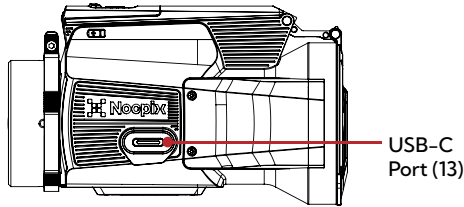

## Using the Battery Charger

To charge the 18650 batteries using the included charger:

- Insert a 18650 battery (16) into the battery charger (17) following the polarity markings (A) inside the battery slot.
- Connect the USB-C cable (15) to the USB-C port (B) on the battery charger.
- Connect the USB end of the cable to an external power source:
  - Any standard USB port on a laptop or computer; OR
  - A 5V–2A USB power adapter (plug the power adapter into an electrical outlet); OR
  - 5 V external power supply, such as a mobile power bank.
- During charging, the LED status indicator (C) is solid red and turns green when charging is complete.
- When charging is complete, disconnect the USB-C cable. Do not overcharge.

**WARNING:** Never use the battery charger with a USB power adapter that is greater than 5V–2A.

**NOTE:** When the LED status indicator flashes red, the battery charger is connected to a power source but no battery is installed.

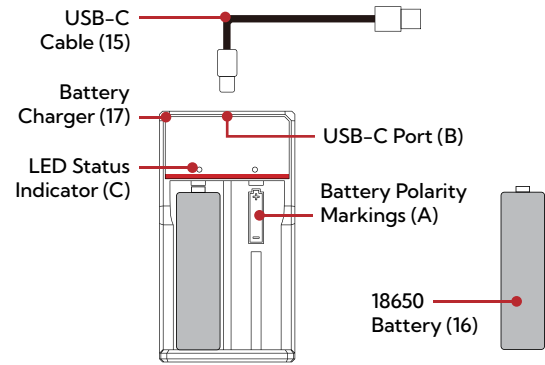

## Installing a 18650 Battery

- Slide the battery release latch (9) back and lift the lid.
- Lay the battery removal strap across the bottom of the compartment and insert a 18650 battery (16).
  - NOTE:** The battery fits very tightly and is difficult to remove without the battery strap (pull the strap to lift the battery).
  - The negative [-] battery terminal faces the front of the MATE Series.
- Tuck in the end of the battery strap and close the lid.
- Slide the release latch forward to lock it.

**WARNING:** The MATE Series can only be powered by an 18650 battery, such as the included IRB–2 batteries. Using any other battery type may cause irreparable damage to the imager or cause a fire. Any damage from using an improper battery will not be covered by warranty.

## Removing a 18650 Battery

- Slide the battery release latch (9) and lift the lid.
- Pull the battery removal strap to lift the battery.
- Remove the battery and close the lid.

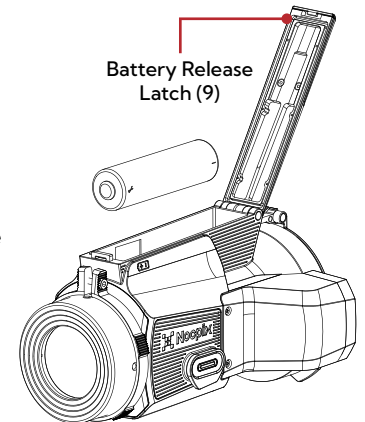

## Battery Safety Warnings

**WARNING:** Only use the factory-supplied battery charger. The use of any other charger may irreparably damage the battery or the charger and may cause a fire. Any damage from using an improper battery charger will not be covered by warranty.

### WARNINGS:

- Use only approved 18650 lithium-ion batteries and specified USB power sources.
- Do not use a battery charger, power adapter, or USB cable that has been modified or damaged.
- Do not expose batteries or the device to excessive heat or open flame. Do not expose batteries to direct sunlight for extended periods.
- Do not immerse batteries in water.
- Do not leave batteries unattended while charging. Do not leave batteries charging for long periods after full charge is reached; charging time should not exceed 24 hours.
- Keep batteries out of the reach of children and pets.
- Batteries are equipped with short-circuit protection. However, any situation that may cause short-circuiting should be avoided.
- Do not puncture, crush, disassemble, modify, or drop batteries.
- Remove and discontinue use of any battery that shows swelling, leakage, unusual odor, or physical damage.
- Do not connect batteries or the device to any external device with a current supply that exceeds the USB 3.0 (5 V) specifications.
- Dispose of batteries in accordance with local regulations for lithium-ion battery recycling; do not dispose of in household waste.

To maintain optimal battery capacity and service life:

- Store batteries in a cool, dry location when not in use, ideally at partial charge for long-term storage.
- Do not charge an extremely cold battery. Allow batteries to warm up for about 45 minutes before charging.
- Charge batteries at a temperature range from 32°F to 113°F; otherwise, the service life of the battery may be reduced.
- The recommended operating temperature range is -4°F to 122°F. Avoid using the batteries above the maximum or below the minimum recommended temperature range as this may decrease the battery capacity or service life.

## 9. Mounting the MATE Series

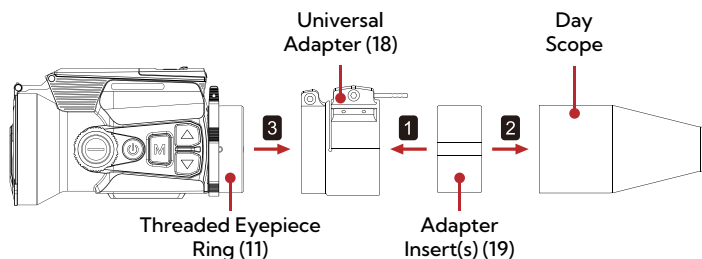

The MATE Series can be mounted to a day scope using the included universal scope adapter (18). The included adapter inserts are suitable for day scopes with an objective outer diameter measuring 56 mm to 65 mm.

**NOTE:** When using the MATE Series mounted to a day scope, set the eyepiece mode to on clip-on mode. See **Main Menu > Eyepiece** on page 54. When clip-on mode is selected, the zeroing distance and profile are shown in the bottom status bar, and the zeroing and recoil activated menu items become available in the main menu.

To mount the MATE Series:

1. Make sure your day scope is zeroed.
2. Measure the outer diameter of your day scope's objective lens.
3. Select the appropriate adapter insert(s) (19) for the diameter of your day scope.
4. Open the adapter's locking lever (20) and slide the insert(s) fully into the adapter ring.
5. Slide the adapter onto the objective lens of your day scope. Press firmly to fully seat it.
6. Close the locking lever.

7. Check to make sure the adapter is securely fitted to the objective lens of your day scope. If there is a gap between the adapter and the lens, you will need to tighten the adapter. To tighten the adapter:
  - a. Use a 2mm hex key to loosen the small set screw (21).
  - b. Use a 4mm hex key to tighten the lever screw (22). Tighten until the adapter fits tightly to the objective lens of the day scope.
  - c. Tighten the set screw (21).

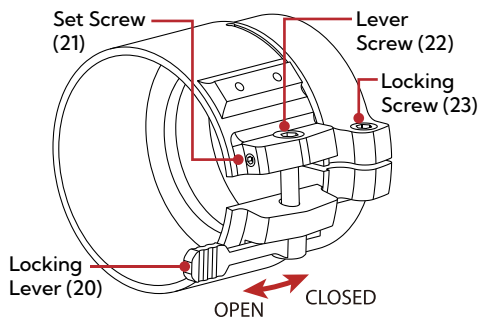

8. Screw the MATE Series onto the end of the adapter, via the threaded eyepiece ring (11).
9. Check to see if the center of the MATE Series's display screen is aligned with the center of the day scope. If the display screen is not in alignment:
  - a. Use a 4mm hex key to loosen the locking socket-head screw (23).
  - b. Adjust the angle of the MATE to the appropriate position to align with the center of your day scope.
  - c. Tighten the locking socket-head screw (23) to secure the MATE Series.
  - d. Adjust the X/Y position of the screen before shooting. See **Zeroing Menu > Zeroing** on page 37 for instructions.

## 10. Operating Instructions

### WARNING!

Don't point the objective lens towards any intense energy sources, such as laser radiation or the sun. This may render the electronic components inoperative. The warranty does not cover damage caused by improper operation.

### Using the Control Buttons

The MATE Series is operated via four control buttons. The control buttons can be used to perform shortcut operations from the home screen, as well as in the menu and full-screen interfaces. See **Description of Control Buttons and Shortcuts** on page 6 for shortcut button details.

### Powering On

1. Open the objective lens cap.
2. Long press the **Power** (⏻) button for 2 seconds to turn on the MATE Series. The Nocpix logo appears.
3. To determine the current battery charge, check the battery status (🔋) icon in the status bar.

### Powering Off

1. Long press the **Power** (⏻) button. The shutdown screen opens, showing a 3-second countdown.
2. Continue holding the **Power** (⏻) button until the countdown completes.
3. "Data saving..." appears on the screen, and the MATE Series shuts down automatically after the data finishes saving.

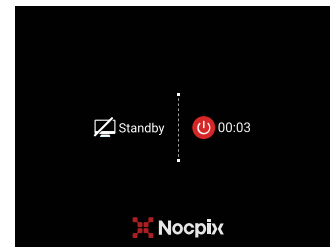

**NOTE:** Releasing the Power button at any time before the 3-second countdown reaches zero will stop the shutdown process, and the MATE Series will enter standby mode. Short press the Power button to exit standby.

**WARNING:** If using an external power supply without a battery, do not remove the power supply when saving data, as the data may not be saved.

## Standby Mode



### AUTOMATICALLY ENTER STANDBY MODE

The MATE Series may be set to enter standby mode automatically. See **Main Menu > Standby** on page 49.

- In the main menu, turn on automatic standby mode. When turned on, the device automatically enters standby when no user is detected. When the built-in proximity sensor detects a face, the device automatically exits standby mode.
  - When automatic standby is turned **ON**:
    - The MATE Series automatically enters standby mode if the vertical tilt angle exceeds 70° or the horizontal tilt angle exceeds 30°.
    - The MATE Series will not enter standby mode while it is in a level (horizontal) position.
  - When auto standby is turned **OFF**, the MATE Series will operate until the battery runs out.
- Press the **Power**  button to exit standby.

### MANUALLY ENTER STANDBY MODE

The user may enter standby mode manually at any time.

- From the home screen, long press the **Power**  button to bring up the shutdown screen.
- Release the **Power**  button before the 3-second countdown finishes to enter standby.
- Short press the **Power**  button to exit standby.

## UI Zooming

In order to adapt to day scopes with different magnification levels, MATE has 4 UI zoom levels.

- Short press the **Down**  button to toggle through the 4 UI levels.

## Focusing the Objective Lens









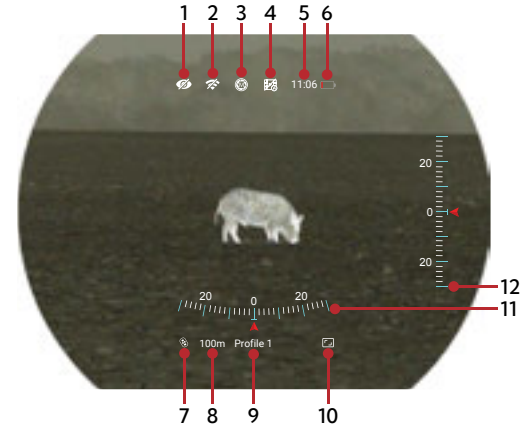





To adjust the focus on the target object:

- Rotate the objective lens focus knob (3) left or right. **NOTE:** Re-adjusting the focus will be necessary if the distance to the target changes.

## Status Bar Overview

The status bars at the top and bottom of the screen show information on the operating status of the MATE Series.



- Ultra-clear Status:** On  or off .
- Wi-Fi/N-Link Status:** Wi-Fi on , Wi-Fi off , N-Link on , N-Link device(s) connected successfully .
- Non-Uniformity Correction (NUC) Mode:** Automatic , Manual , or Background .
- Recoil-Activated Video (RAV) Status:** On  or off .
- Time:** Shows the current time in 24-hour format.
- 18650 Battery Status:** Shows the status of the 18650 battery. The color/fill level indicates the remaining battery charge. The charging battery  icon appears when the imager is connected to an external power source.
- Remote Status:** The remote  icon appears when the remote is connected.
- Zero Distance (Clip-on Mode Only):** Shows the selected zero distance
- Zeroing Profile (Clip-on Mode Only):** Shows the selected zeroing profile.
- Magic Zoom:** The Magic Zoom  icon appears when Magic Zoom is connected.
- Tilt (Horizontal) Angle:** Appears when the motion sensor is turned on.
- Pitch (Vertical) Angle:** Appears when the motion sensor is turned on.

## Navigating the Quick Menu

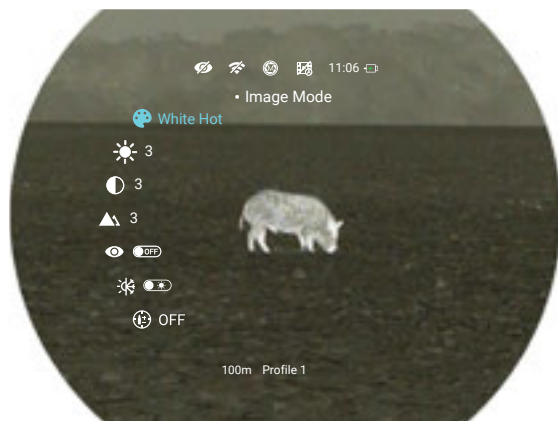

In the quick menu, the following commonly used settings can be quickly adjusted: color palette, screen brightness, image contrast, image sharpness, Ultra-Clear mode, image hue, and preset ballistic calculation (BC) distance.

- On the home screen, short press the **Menu [M] button** to enter the quick menu.
- Short press the **Up [▲] and Down [▼] buttons** to move through the quick menu options. The menu icons turn blue to indicate the cursor position in the quick menu.
- Short press the **Menu [M] button** to toggle through the parameters for the selected menu option.
- Long press the **Menu [M] button** to save any changes and return to the home screen.
- After 7 seconds of inactivity, the system automatically saves any changes, and returns to the home screen.

**NOTE:** See **Quick Menu Options and Descriptions** on page 30 for detailed information about the quick menu options.

## Navigating the Main Menu



- On the home screen, long press the **Menu [M] button** to enter the main menu.
- Short press the **Up [▲] and Down [▼] buttons** to move through the main menu options. The text and menu icons turn blue to indicate the cursor position in the menu.
- Short press the **Menu [M] button** to:
  - Change the parameters for the selected menu option; **OR**
  - Enter the submenu; **OR**
  - Confirm submenu changes and return to the previous menu.
- Long press the **Menu [M] button** to confirm any changes and return to the home screen.
- Short press the **Power [⏻] button** to return to the previous menu without saving.
- After 7 seconds of inactivity, the menu automatically closes, and the interface returns to the home screen. Changes (except changes to toggle on / off menu items, such as Ultra-Clear and Wi-Fi) are not saved automatically.

**NOTE:** See **Main Menu Options and Descriptions** on page 34 for detailed information about the main menu options.

## 11. Non-Uniformity Correction

A non-uniformity correction (NUC) allows a thermal imager's sensors to correct its pixels and eliminate any image defects caused by pixel drift. A NUC is performed automatically each time the MATE Series is powered on. The MATE Series has three NUC modes, automatic, manual, and background. See **Main Menu > Calibration** on page 48 for instructions for selecting the NUC mode.

### Automatic Mode

In automatic mode, the MATE Series will perform a NUC automatically according to the internal software algorithm. There is no need to close the objective lens cap as the MATE Series's internal shutter covers the sensor.

**NOTE:** A manual NUC (see below) may be performed at any time while in Automatic mode.

### Manual Mode

In manual mode, the user independently determines the need to perform a NUC based on the quality of the observed image. It is not necessary to close the objective lens cap during a manual NUC, as the internal shutter covers the sensor.

To perform a manual NUC while in manual or automatic mode:

1. From the home screen, short press the **Power**  **button**.
2. The internal shutter covers the sensor, and a manual NUC is performed instantly.

### Background Mode

In background mode, the user independently determines the need to perform a background NUC based on the quality of the observed image. A background NUC uses less power than an automatic or manual NUC because it does not use the imager shutter to cover the sensor; instead, the user must close the lens cap.

To perform a background NUC while in background mode:

1. Close the objective lens cap (1).
2. From the home screen, short press the **Power**  **button**.
3. A prompt to close the lens cap appears onscreen. The background NUC starts after about 2 seconds.

**NOTE:** If the lens is not properly covered, a temporary "image burn" will remain in the image until the next non-uniformity correction. This image burn is temporary and is not a defect or sign of permanent damage.



## 12. Photography and Video Recording

The MATE Series is equipped with video recording and image capture. Photos and videos are automatically saved to the built-in 64 GB memory storage.

**NOTE:** Photo and video files are named with the time and date; therefore, it is recommended to set the date and time before using the photo and video functions. See **Settings > Date and Time** on page 55. Alternatively, the date and time may be synchronized in the NOCPIX App.

### Photography

To take a photo:

1. From the home screen, double-click the **Down**  **button**.
2. The camera  icon appears briefly in the upper-right corner of the screen.





**NOTE:** A red warning icon  appears next to the camera icon when insufficient memory storage is available. Transfer video and image files to other storage media to free up space on the memory card.

### Video Recording

To record video:

1. Turn on the microphone in the main menu. See **Main Menu > Microphone** on page 49.
2. From the home screen, long press the **Down**  **button** to start a video recording.
3. When the video recording starts, the video recording timer, in HH:MM:SS (hour, minute, second) format, appears in the upper-right corner of the screen.



4. When recording, short press the **Down**  **button** to take a photo.
5. Long press the **Down**  **button** to stop and save the video recording.

## Recoil Activated Video (RAV)

When recoil activated video is turned on, the device records 10 seconds before each shot and 20 seconds after the shot. A slow-motion video of the bullet impact is also captured. See **Main Menu > Recoil Activated Video** on page 22 for instructions.

### NOTES:

- When multiple shots are taken within the same 30-second period, only one video is recorded.
- When recoil activated video recording is turned on, standard video recording is unavailable.

## Video and Photography Notes

- You may enter and navigate the menu during video recording.
- Recorded photos and videos are saved to the memory card.
  - Photos are saved as PIC\_HHMMSS.jpg.
  - Videos are saved as VID\_HHMMSS.mp4.
  - RAV videos are saved as RAV\_HHMMSS.mp4. Slow-motion bullet impact is saved as RAV\_HHMMSS\_SLOW.mp4.
  - HHMMSS is hour, minute, and second.
- The number of recorded files is limited only by the capacity of the internal memory.
- Regularly check the available memory storage space and move video footage and images to other storage media to free up space on the memory card.

## 13. Accessing the Internal Memory

When the MATE Series is turned on and connected to a computer via the included USB-C data cable, it is recognized by the computer as a flash memory (USB) drive. This allows the user to access the saved multimedia files and copy or delete any desired files.

To access the internal memory:

1. Turn on the MATE Series.
2. Connect the device to your computer via the included USB-C cable (15).

3. Double-click **My Computer** on your computer desktop.
4. Double-click to open the device named **NOCPIX**.
5. Double-click to open the device named **MATE S60R** to access the built-in memory. Recorded photos and videos are separated into folders by date, YYYYDDMM.
6. Select the desired files or folders to copy or delete.

## 14. Using the NOCPX App

The MATE Series can be operated using the NOCPX App when connected to a tablet or smartphone or via Wi-Fi.

1. Download the App for free and install it on your device:
  - a. Scan a QR code to download it from the App Store or Google Play; **OR**
  - b. Download the App from any app store.
2. Connect the MATE Series to Wi-Fi:
  - a. Turn on the Wi-Fi. See **Main Menu > Wi-Fi** on page 25 for instructions.
  - b. Open the App and click the **Connect Device** button. Then, click **Connect Phone WLAN**.
  - c. On the mobile device, go to **Settings > Wi-Fi**.
  - d. Select the MATE Series from the list of Wi-Fi networks: "MATE ULTRA S60R\_XXXXXXX" where XXXXXXX is the device serial number.
  - e. Enter the Wi-Fi password and tap the **Join** button. The default password is 12345678.
3. Operate the MATE Series via the App:
  - a. Take real-time photos and videos, with or without audio.
  - b. View, share, download, and delete photos and videos taken via the App, which are saved to the mobile device.
  - c. Change the Wi-Fi password and SSID.
  - d. Synchronize the date and time from the mobile device.
  - e. Update the MATE Series firmware.

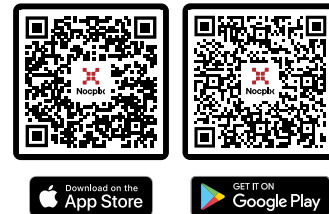

**NOTE:** When a factory reset is performed, the Wi-Fi SSID and password are reset to the defaults, MATE ULTRA S60R\_XXXXXXX and 12345678. See **Settings > Factory Reset** on page 57.

## 15. Remote Control

The MATE Series and the included remote control are paired at the factory before shipping.

To use the remote control

1. Remove the remote control from its plastic base.
2. Charge the remote control fully before using it for the first time.
3. Attach the remote to the weapon:
  - a. Thread the included velcro strap through the slots in the base and replace the remote.
  - b. Use the velcro straps to attach the remote to the stock/handguard.
4. Turn on the MATE Series.
5. The remote  icon appears in the bottom-left corner to indicate that it is successfully connected to the device.



### Charging the Remote Control



1. Place the remote in its charging slot in the battery charger/case.
2. Connect the USB-C cable (15) to the battery charger.
3. Connect the USB end of the cable to an external power source:
  - a. Any standard USB port on a laptop or computer; OR
  - b. A 5V-2A USB power adapter (plug the power adapter into an electrical outlet); OR
  - c. 5V external power supply, such as a mobile power bank.
4. The LED status indicator is red during charging, and turns green when charging is complete.
5. When charging is complete, disconnect the USB-C cable. Do not overcharge.

**WARNING:** Never use the battery charger with a USB power adapter that is greater than 5V-2A.

### Re-Pairing the Remote

If you replace the remote in the future, the new remote will need to be paired to the MATE Series:

1. Turn on the MATE Series.

2. Press and hold the **Menu**  and **Down**  buttons on the remote at the same time for 10 seconds.
3. The remote  icon appears in the bottom-left corner when it is successfully connected to the MATE.

## 16. Integrated Laser Rangefinder

The MATE Series is equipped with an integrated, precision laser rangefinder, which allows the user to measure the distance to objects up to 1,300 yards away, with  $\pm 1$ -yard accuracy. The laser rangefinder has two ranging modes: continuous and single-measurement capture. Continuous ranging allows the user to adjust quickly to changing distances for better shot placement.



**CAUTION:** Do not stare directly into the laser.

The rangefinder interface has the following features:



- **Cursor:** The ranging cursor  appears in the center of the screen.
- **Rangefinding measurement:** The target distance.
- **Mode:** The selected ranging mode, CONT (continuous) or SGL (single).
- **Ballistic Calculation (Single Ranging Only):**
  - When BC image calibration is turned OFF, the ballistic calculation is displayed.
  - When BC image calibration is turned ON, the MATE Series will automatically adjust the zeroing distance to the LRF target distance based on the ballistic calculation results. "BC Image Calibrated / Zeroing Distance XXXm" is displayed instead of the calculated ballistic drop.
  - See **Zeroing > BC Image Calibration** on page 40.

### NOTES:

- Ballistic calculation can only be performed when performing single ranging.
- The LRF cursor color and brightness level can be customized, and continuous LRF mode can be turned on or off in the main menu; see **Main Menu > Laser Rangefinder** on page 46 for instructions.

- When continuous ranging is active, the distance to the target indicated by the LRF cursor will be refreshed automatically by the rangefinder every second.
- To change the units of measurement (meters or yards), see **Settings > Unit** on page 57.



#### When continuous LRF mode is ON:

- Short press the **Up**  button to perform a single ranging measurement. **SGL: XXXm** and the ballistic calculation will be displayed.
- Long press the **Up**  button to begin continuous ranging. **CONT: XXXm** will be displayed. Short press the **Power**  button to exit continuous ranging.

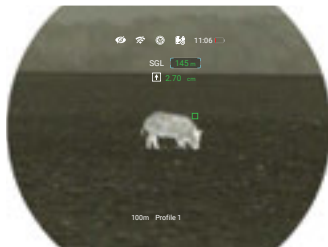
**NOTE:** Ballistic calculation is disabled in continuous ranging mode.



#### When continuous LRF mode is OFF:

- Short press the **Up**  button to perform a single ranging measurement. **SGL: XXXm** and the ballistic calculation will be displayed.
- Long press the **Up**  button, move the LRF cursor to the target, then release the Up button to trigger a single ranging measurement. **SGL: XXXm** will be displayed.

#### Rangefinding Accuracy

- The measurement accuracy and maximum range depend on the reflection ratio on the target surface, the angle at which the laser beam falls on the target surface, and environmental conditions. Reflectivity depends on the surface texture, color, size, and shape of the object. Typically, a glossy, bright surface will have higher reflectivity than a darker surface.
- Ranging performance can degrade in bright conditions or when ranging towards the sun.
- The measurement accuracy can be affected by fog, smog, heavy rain, snow, and other weather conditions. It can also be affected by a low battery or a dirty or smudged objective lens.

- Measuring the range to a small target is more difficult than measuring the range to a large target.

## 17. Magic Zoom

Magic Zoom automatically adapts both the thermal image and user interface in real time when zooming through your rifle scope. Supported by R+ and AI technology, Magic Zoom delivers seamless scaling, sharper details, and perfect alignment at every magnification. AI-assisted processing ensures that your view remains fast, smooth, and always focused on the target, whether hunting in dense foliage or scanning open terrain.

### Using the Magic Zoom

The MATE Series and Magic Zoom accessory are paired at the factory before shipping. **NOTE:** If you upgrade the MATE Series firmware or replace the Magic Zoom, you will need to re-pair the Magic Zoom using the steps below.

Before using the Magic Zoom, you will need to:

1. Install a battery. See **Installing the Battery** on the next page.
2. Mount the MATE Series on the front of the day scope.
3. Use one of the included straps to attach the Magic Zoom to the magnification adjustment ring of the day scope.
4. Turn on the MATE Series.
5. Calibrate the Magic Zoom following the steps in **Calibrating the Magic Zoom** on page 29.

Using the Magic Zoom after calibration:

1. Press and hold the Power button to turn the Magic Zoom on or off. When connected, the Magic Zoom  icon will appear in the bottom-right corner of the screen.
2. During use, when the status LED is green, the battery is full; when the LED is red, the battery is low and should be charged promptly.



## Magic Zoom Battery Overview

### INSTALLING THE BATTERY

1. Locate a Magic Zoom battery in the battery charger/case.
2. Remove the protective film from the battery electrodes.
3. Fully charge the battery before use.
4. Slide the battery into the slot at the top of the Magic Zoom. The battery icon on the battery must be on the same side as the Magic Zoom Power button. **NOTE:** When positioned properly, the battery will slide in easily; if sliding is difficult, flip the battery around and try again.

### REMOVING THE BATTERY

1. Press the raised lines on the back of the battery and slide it forward to remove.

### CHARGING THE BATTERY

2. Insert the battery into a charging slot in the battery charger/case. The battery will click into place when properly positioned. If the battery does not click into place, flip it over and try again.
3. Connect the USB-C cable (15) to the battery charger.
4. Connect the USB end of the cable to an external power source:
  - a. Any standard USB port on a laptop or computer; OR
  - b. A 5V–2A USB power adapter (plug the power adapter into an electrical outlet); OR
  - c. 5 V external power supply, such as a mobile power bank.
5. The LED status indicator is red during charging, and turns green when charging is complete.
6. When charging is complete, disconnect the USB-C cable. Do not overcharge.

**WARNING:** Never use the battery charger with a USB power adapter that is greater than 5V–2A.

## Calibrating the Magic Zoom

**NOTE:** If Magic Zoom is removed from the day scope, it must be recalibrated upon re-installation.

1. In the main menu, select the **Magic Zoom** menu option.
2. A popup window shows the message “MAGIC ZOOM Calibration?” and two options, Yes and No.
3. Short press the **Menu** **M** button to select **Yes** to begin calibrating the Magic Zoom; or select **No** to cancel the calibration and exit.
4. During the calibration process, keep the rifle within 30 degrees of the vertical tilt angle.
5. Make sure the Magic Zoom is installed on the magnification adjustment ring of the day scope, then short press the **Menu** **M** button to select **Next**.
6. Adjust the day scope to 3X\*, then short press the **Menu** **M** button to select **Next**.
7. Adjust the day scope to 6X\*, then short press the **Menu** **M** button to select **Next**.
8. Adjust the day scope to 9X\*, then short press the **Menu** **M** button to select **Next**.
9. A popup window shows the message “Calibration completed, Let’s start Magic Zoom,” indicating that Magic Zoom has been calibrated and can now be used normally.

\*If your day scope does not have 3X/6X/9X magnification, choose the closest magnification.

**BATTERY REPLACEMENT NOTE:** Do not remove the Magic Zoom from the day scope when replacing the battery, as this will require recalibration.

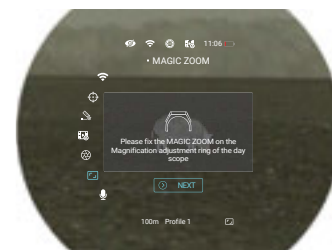

## Re-Pairing the Magic Zoom

If you upgrade the MATE Series firmware or replace the Magic Zoom, you will need to reconnect the Magic Zoom using the steps below.

**IMPORTANT:** Perform the following pairing steps within the first 90 seconds of turning on the MATE Series.

1. Long press the Power button on the side of the Magic Zoom for 3 seconds.
2. The status LED will turn green and then turn off, indicating that Magic Zoom is on.
3. Short press the Magic Zoom Power button 6 times.
4. The status LED will flash red for each of the first 5 short presses. After the 6th short press, the status LED will stay red for 3 seconds and then turn off, indicating that Magic Zoom is connected to the MATE Series.
5. Wait for 10 seconds, the Magic Zoom icon will appear in the bottom-right corner of the MATE Series screen, indicating that Magic Zoom is successfully connected.
6. After the connection is successful, short press the Magic Zoom Power button.
7. After successfully pairing the MATE Series and Magic Zoom, complete the calibration steps below.

## 18. Quick Menu Options and Descriptions

1. Short press the **Menu** button to enter the quick menu.
2. Short press the **Up/Down buttons** to move through the quick menu options. The selected menu option changes from white to blue.
3. Short press the **Menu** button to toggle through the options for each menu item.
4. Long press the **Menu** button to confirm the selection and exit.

### Quick Menu Structure:

- Color Palette, Screen Brightness, Image Contrast, Image Sharpness, Ultra-Clear Mode, Image Hue, and Preset Ballistic Calculation Distance.

## Color Palette

### Set the color palette

1. In the quick menu, short press the **Up/Down buttons** to select **Color Palette**.
2. Short press the **Menu** button to toggle through the color palette options: white hot, black hot, red hot, rainbow, violet, crimson, and viridian.
3. Long press the **Menu** button to confirm and exit.

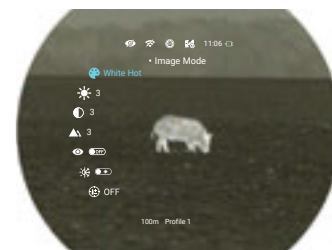

## Screen Brightness / Image Contrast / Image Sharpness

### Set the screen brightness, image contrast, or image sharpness

1. In the quick menu, short press the **Up/Down buttons** to select **Screen Brightness**, **Image Contrast**, or **Image Sharpness**.
2. Short press the **Menu** button to toggle through levels 1 to 6.
3. Long press the **Menu** button to confirm the selection and exit.

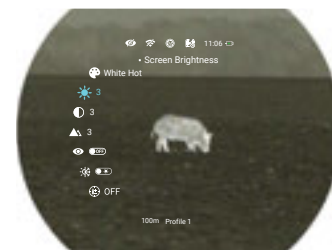

## Ultra-Clear

### Turn Ultra-Clear mode on or off

Ultra-Clear mode enhances the image contrast and quality in rainy, foggy, or low-contrast conditions.





1. In the quick menu, short press the **Up/Down buttons** to select **Ultra-Clear**.
2. Short press the **Menu** button to toggle Ultra-Clear ON or OFF. The Ultra-Clear status, on or off, appears in the status bar.
3. Long press the **Menu** button to confirm the selection and exit.



**NOTE:** When Ultra-Clear is turned on and off, the MATE automatically performs a shuttered non-uniformity correction.

## Image Hue

### Set the image hue mode



1. In the quick menu, short press the **Up/Down buttons** to select **Image Hue** .
2. Short press the **Menu**  **button** to toggle between the options:
  - a. **Warm**  (toggle ON): Provides a softer image and reduces eye strain.
  - b. **Cool**  (toggle OFF): Provides increased contrast and image brightness.
3. Long press the **Menu**  **button** to confirm the selection and exit.

**NOTE:** Image hue is available when using the white hot or black hot color palette.



## Preset Ballistic Calculation Distance

### Select a preset distance, or add/edit the quick distance





1. In the quick menu, short press the **Up/Down buttons** to select **Preset Ballistic Calculation Distance** .
2. Short press the **Menu**  **button** to toggle through the options: 200m, 225m, 250m, 275m, 300m, +, and OFF.
  - a. **OFF:** The preset BC distance function is not enabled.
  - b. **Preset BC distances (200m, 225m, 250m, 275m, 300m by default):** Ballistic calculation will be performed according to the selected preset distance.



- i. Go to **Zeroing > BC Distance** on page 43 to edit the preset BC distances.
- c. **+**: Add a quick BC distance (see instructions below).

**NOTE:** When preset BC distance is enabled, tilt the device until it enters auto standby, enter the quick menu or main menu, or shut down the device to stop using the preset BC distance.

To add a quick BC distance:

1. When **+** is selected, press and hold the **Menu**  **button**.
2. "000" appears with a blue arrow above and below the far-left digit to mark the cursor location.
3. To manually set the quick BC distance:
  - a. Short press the **Up/Down buttons** to increase or decrease the value of the selected digit from 0 to 9.
  - b. Short press the **Menu**  **button** to switch between the three digits. The two blue arrows move to indicate the selected digit.
4. To set the LRF ranging distance as the quick BC distance:
  - a. Short press the **Menu**  **button** until the LRF  icon is selected.
  - b. Short press the **Up button**. The LRF cursor will appear in the center of the screen, and a single ranging measurement will be taken.
5. Long press the **Menu**  **button** to save the quick BC distance.
6. The quick menu will close after 7 seconds of inactivity.

**NOTE:** The quick BC distance can only be edited from the quick menu. To edit, select preset BC distance , short press Menu to toggle through the preset BC distances, and when the quick BC distance is selected, long press Menu to begin editing it.



## 19. Main Menu Options and Descriptions

1. Long press the **Menu** **M** button to enter the main menu.
2. Short press the **Up/Down** buttons to move through the main menu options. The selected option changes from white to blue.
3. Short press the **Menu** **M** button to toggle through the options for each menu item.
4. Long press the **Menu** **M** button to confirm; or short press the **Power** **⏻** button to exit.

### Main Menu Structure:

- **Main Menu:** Wi-Fi, Zeroing, Laser Rangefinder, Recoil Activated Video, Calibration, Magic Zoom, Microphone, Standby, Pixel Defect Correction, Motion Sensor, Gallery, Eyepiece, Settings
- **Zeroing Menu:** Zeroing, Ballistic Calculation, BC Units, BC Image Calibration, BC Parameters, BC Distance, Ref. Line, Ref. Line Color, Ref. Line Calibration, Delete
- **Laser Rangefinder Menu:** LRF Mark Color, LRF Mark Brightness, Continuous LRF
- **Settings Menu:** Date, Time, Languages, Custom Palettes, Unit, Firmware Update, Factory Reset, Info

**NOTE:** The Zeroing and Recoil Activated Video menu items are only available in clip-on mode. Go to **Main Menu > Eyepiece** on page 54 to select clip-on mode.

### Wi-Fi

#### Turn Wi-Fi or N-Link on or off



Turn on Wi-Fi to operate the MATE Series via the NOCPIX App. Turn on N-Link to pair the MATE Series with another NOCPIX device to share single-measurement rangefinding data.

1. In the main menu, **Wi-Fi**  is selected by default.
2. Short press the **Menu** **M** button to select it and enter the Wi-Fi submenu.



### WI-FI > WI-FI TOGGLE

#### Turn Wi-Fi on or off



1. In the Wi-Fi submenu, short press the **Menu** **M** button to turn the **Wi-Fi toggle** ON or OFF. The Wi-Fi status, on  or off , appears in the status bar.
2. Long press the **Menu** **M** button to confirm and exit.



### WI-FI > N-LINK

#### Turn N-Link on or off

To connect the MATE Series to another NOCPIX device via N-Link:

1. On the other NOCPIX device: turn on Wi-Fi.
2. On the MATE: In the Wi-Fi submenu, short press the **Up/Down** buttons to move to the **N-Link toggle**, and short press the **Menu** **M** button to turn it on.
3. When N-Link is turned on, a list of nearby NOCPIX devices is displayed, and the N-Link  appears in the status bar.
4. Short press the **Up/Down** buttons to move to the desired NOCPIX device, and short press the **Menu** **M** button to select the device to connect to it.
5. When the MATE Series is successfully connected to another NOCPIX device, a checkmark appears to the right of the device name, and the N-Link device(s) connected  icon appears in the status bar.
6. Long press the **Menu** **M** button to confirm and exit.









#### NOTES:

- When a single rangefinder measurement is taken on the MATE Series, the distance and image view will be transmitted to the connected NOCPIX device. Continuous rangefinding data cannot be shared.

- If the Ballistic calculation function is turned on in the connected NOCPIX device, ballistic calculation can be performed using the transmitted ranging measurement.
- Wi-Fi and N-Link cannot be used at the same time; when one is turned on, the other is automatically turned off.

## Zeroing (Clip-On Mode Only)

### Adjust the zeroing and ballistic calculation settings

1. In the main menu, short press the **Up/Down buttons** to select **Zeroing** .
2. Short press the **Menu**  **button** to enter the submenu.
3. Short press the **Menu**  **button** to select the default zeroing profile, **Profile 1**; OR
4. Add a new zeroing profile:
  - a. Short press the **Up/Down buttons** to move to the **Add**  **icon**.
  - b. Short press the **Menu**  **button** to add a new profile. Profiles are named "Profile [1/2/3/4/5/6/7/8]" by default.
5. Short press the **Power**  **button** to return to the previous menu; **OR**
6. Long press the **Menu**  **button** to exit.







**NOTE:** The zeroing profile names and parameters can be edited in the NOCPIX App.



## ZEROING > ZEROING

### Adjust the position of the screen in clip-on mode

In clip-on mode, the display size is reduced to be in unity (1x). On your first use, it may be necessary to adjust the X/Y of the screen to collimate the MATE Series to your day scope reticle. If your POI and POA differ in clip-on mode, adjust the screen position following the instructions below.

1. In the submenu for the selected zeroing profile, **Zeroing**  is selected by default. Short press the **Menu**  **button** to select it and enter the zeroing interface.
2. The zeroing interface has the following features:
  - 1 **Y-Axis**  **Icon:** Vertical point of impact change (in cm or inches).
  - 2 **X-Axis**  **Icon:** Horizontal point of impact change (in cm or inches).
  - 3 **Zero Distance:** Select to set the desired zero distance.
  - 4 **Freeze**  **Toggle:** Turn the toggle on to freeze the image; turn it off to unfreeze the image.
3. Edit the zero distance or use the LRF ranging distance
  - a. Short press the **Up/Down buttons** to move to the zeroing distance.
  - b. Short press the **Menu**  **button** to begin editing it. A blue arrow appears above and below the far-left digit to mark the cursor location.

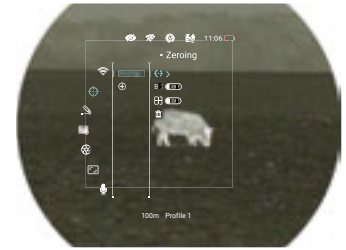

- c. To manually set the zero distance:
  - i. Short press the **Up/Down buttons** to increase or decrease the value of the selected digit from 0 to 9.
  - ii. Short press the **Menu (M) button** to switch between the three digits. The two blue arrows move to indicate the selected digit.

- d. To set the LRF ranging distance as the zeroing distance:

- i. Short press the **Menu (M) button** until the LRF icon is selected.
  - ii. Short press the **Up button**. The LRF cursor will appear in the center of the screen and a single ranging measurement will be taken.
- e. To stop editing, short press the **Menu (M) button** until the blue arrow editing arrows disappear.



4. Center the reticle on the aiming point and freeze the image view.

- a. Short press the **Up/Down buttons** to move to the image freeze  toggle.
- b. Short press the **Menu (M) button** to turn on the toggle to freeze the image. Turn off the toggle to unfreeze the image.



5. Select the axis (X or Y) along which to adjust the X/Y position of the screen:

- a. Short press the **Up/Down buttons** to move between X and Y. The icon changes from white to blue to mark the cursor location.
- b. Short press the **Menu (M) button** to select the desired axis. The axis flashes to indicate that it is selected.



6. Adjust the X/Y position of the screen to collimate the MATE Series to your day scope reticle:

- a. **X** (horizontal) is the windage and **Y** (vertical) is the elevation.
- b. Use the **Up button** to move in the positive direction: X= Right and Y= Up.



- c. Use the **Down button** to move in the negative direction: X= Left and Y= Down.
- d. Short press the **Up/Down buttons** to move the screen in the corresponding direction by 1 pixel; long press to move 10 pixels.

7. Short press the **Menu (M) button** to save the position for the selected axis and deselect it. When deselected, the axis will stop flashing.
8. Repeat steps 5 to 7 to adjust the screen position along the second axis if needed.
9. Short press the **Power (⊙) button** to exit the interface without saving the screen position; **OR**
10. Long press the **Menu (M) button** to confirm changes.

- a. A popup window shows the message "Do you want to keep these settings?" and two options, Yes and No. Yes is selected by default.
- b. Short press the **Menu (M) button** to select **Yes** to save the screen position.
- c. Short press the **Up/Down buttons** to move to **No**, and short press the **Menu (M) button** to exit to the main menu without saving.



11. Take a confirmation shot—the point of impact should now match the point of aim. If not, adjust the X/Y position of the screen again.

## ZEROING > BC ON/OFF BC

### Turn ballistic calculation on or off

1. In the zeroing submenu, short press the **Up/Down buttons** to select **BC On/Off BC**.
2. Short press the **Menu (M) button** to turn ballistic calculation ON or OFF.
3. Long press the **Menu (M) button** to confirm the selection and exit.

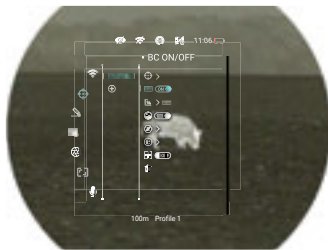

## ZEROING > BC UNITS

### Set the ballistic calculation units of measurement

1. In the zeroing submenu, short press the **Up/Down buttons** to select **BC Units **.
2. Short press the **Menu (M) button** to enter the submenu.
3. Short press the **Up/Down buttons** to move through the unit toggles.
4. Short press the **Menu (M) button** to turn the toggles ON or OFF.
  - a. Set the angular units to **MOA** or **mil**.
  - b. Set the linear units to **cm** or **inches**.
5. Long press the **Menu (M) button** to confirm the selection and exit.

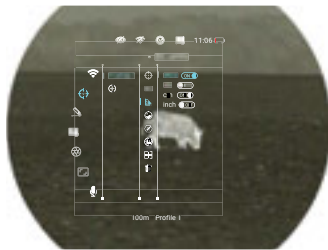

## ZEROING > BC IMAGE CALIBRATION

### Turn ballistic calculation image calibration on or off

1. In the zeroing submenu, short press the **Up/Down buttons** to select the **BC Image Calibration **.
2. Short press the **Menu (M) button** to turn the ballistic calculation image calibration ON or OFF:

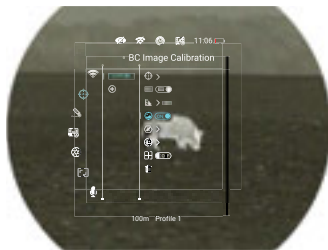

- a. **OFF:** The ballistic calculation will display on the screen.

As shown in the figure, the zeroing distance is 100m, and the ballistic correction result is 2.7cm up at the 145m target distance. The shooter will need to convert 2.7cm up into the day scope's reticle scale (MIL/MOA), then aim and shoot according to the new position on the day scope.



- b. **ON:** Instead of showing the ballistic correction, the MATE Series will calculate the bullet drop from the ballistic calculations, and digitally shift the thermal image relative to the day scope reticle, and align the corrected impact point with the reticle center of the day scope. The shooter can aim normally at the target without needing to calculate a new POA. As shown in the figure, the zeroing distance has been temporarily set to 146m according to the ranging measurement, and the prompt "BC Image Calibrated" "Zeroing Distance: 146m" is displayed on the screen.



3. Long press the **Menu (M) button** to confirm the selection and exit.

To clear the BC image calculation for the target distance and return to the default zeroing distance:









1. Press the **Power (Ⓢ) button** to exit; **OR**
2. Enter quick menu or main menu; **OR**
3. Tilt the device until it enters auto standby.

The "BC Image Calibrated / Zeroing Distance 146m" prompt will disappear, indicating that the original zeroing distance (100m in our example) has been restored.



## ZEROING > BC PARAMETER

### Set parameters for bullets, rifles, and the environment



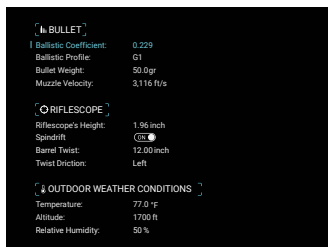
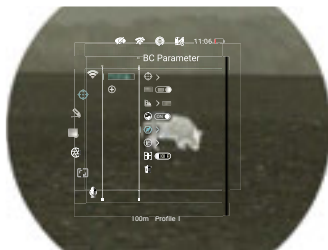

1. In the zeroing submenu, short press the **Up/Down** buttons to select **BC Parameter** .
2. Short press the **Menu**  button to enter the submenu.
3. Short press the **Up/Down** buttons to move to a parameter, and short press the **Menu**  button to begin editing it:
  - a. Short press the **Menu**  button to toggle through non-numerical options.
  - b. When editing numerical values:
    - i. A blue arrow appears above and below the far-left digit to mark the cursor location.
    - ii. Short press the **Up/Down** buttons to increase or decrease the value of the selected digit from 0 to 9.
    - iii. Short press the **Menu**  button to switch between the digits. The two blue arrows move to indicate the selected digit.
  - c. Short press the **Power**  button to exit without saving; **OR**
  - d. Long press the **Menu**  button to confirm and return.
4. When all parameters have been edited:
  - a. Short press the **Power**  button to exit the parameters interface without saving; **OR**
  - b. Long press the **Menu**  button to confirm all parameter changes and return to the previous menu.



**NOTE:** The ballistic parameters can be adjusted in the NOCPPIX App.

## ZEROING > BC DISTANCE

### Edit the preset ballistic calculation (BC) distances that appear in the quick menu



1. In the zeroing submenu, short press the **Up/Down** buttons to select **BC Distance** .
2. Short press the **Menu**  button to enter the submenu.
3. Short press the **Up/Down** buttons to move to a BC distance, and short press the **Menu**  button to begin editing it:
  - a. A blue arrow appears above and below the far-left digit to mark the cursor location.
  - b. Short press the **Up/Down** buttons to increase or decrease the value of the selected digit from 0 to 9.
  - c. Short press the **Menu**  button to switch between the three digits. The two blue arrows move to indicate the selected digit.
4. Long press the **Menu**  button to confirm the changes and exit.



## ZEROING > REF. LINE

### Turn the ref. line on or off

The ref. line is a digital crosshair that is overlaid on recorded video to indicate the rifle's point of aim. The overlay is not displayed live in the image view to avoid interfering with the day scope reticle.

1. In the zeroing submenu, short press the **Up/Down** buttons to select **Ref. Line** .
2. Short press the **Menu**  button to turn the ref. line ON or OFF.
3. Long press the **Menu**  button to confirm the selection and exit.

**NOTE:** The ref. line feature is automatically disabled to meet regulatory requirements when operating the MATE Series through the NOCPPIX APP.

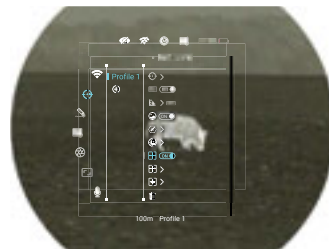

## ZEROING > REF. LINE COLOR

### Adjust the color of the ref. line

1. In the zeroing submenu, short press the **Up/Down buttons** to select **Ref. Line Color** .
2. Short press the **Menu (M) button** to enter the submenu.
3. Short press the **Up/Down buttons** to move through the color options, Blue, Green, Red, White, and Black.
4. Long press the **Menu (M) button** to confirm the selection and exit.



## ZEROING > REF. LINE CALIBRATION

### Align the ref. line overlay with the center of the day scope crosshair

1. In the zeroing submenu, short press the **Up/Down buttons** to select **Ref. Line Calibration** .
2. Short press the **Menu (M) button** to enter the calibration interface.
3. The interface has the following features:
  - 1 **Y-Axis  $\updownarrow$  Icon:** Move the ref. line vertically.
  - 2 **X-Axis  $\leftrightarrow$  Icon:** Move the ref. line horizontally.
  - 3 **Ref. Line Cursor:** Shows the ref. line position.



To calibrate the ref. line:

1. Short press the **Up/Down buttons** to move between **X** and **Y**. The axis icon turns from white to blue to indicate the cursor location.
  - a. Short press the **Menu (M) button** to select **X** or **Y**. The selected axis begins flashing.
2. Adjust the X/Y position of the ref. line until it aligns with the day scope crosshairs.
  - a. **X** (horizontal) is the windage and **Y** (vertical) is the elevation.
  - b. Use the **Up button** to move in the positive direction: X= Right and Y= Up.

- c. Use the **Down button** to move in the negative direction: X= Left and Y= Down.
- d. Short press the **Up/Down buttons** to move the cursor in the corresponding direction by 1 pixel; long press to move 10 pixels.
3. Short press the **Menu (M) button** to save the position for the selected axis and deselect it. When deselected, the axis stops flashing.
4. Repeat steps 1 to 3 to adjust the ref. line position along the second axis if needed.
5. When done, long press the **Menu (M) button**. A popup window shows the message "Do you want to keep these settings?" and two options, Yes and No. Yes is selected by default.
6. Short press the **Menu (M) button** to select **Yes** to save the new X/Y coordinates.
7. Short press the **Up/Down buttons** to move to **No**, and short press the **Menu (M) button** to exit to the main menu without saving.

## ZEROING > DEL



### Delete the selected zeroing profile

1. In the zeroing submenu, short press the **Up/Down buttons** to select **Delete** .
2. Short press the **Menu (M) button** to delete the selected zeroing profile.
3. A popup window shows the message "Delete this profile?" and two options, No and Yes. Yes is selected by default.
4. Short press the **Menu (M) button** to select **Yes** to return to delete the zeroing profile and return to the previous menu; **OR**
5. Short press the **Up/Down buttons** to select **No**, and short press the **Menu (M) button** to return to the previous menu without deleting the zeroing profile.



## Laser Rangefinder



### Customize the rangefinder cursor and turn continuous LRF on or off

1. In the main menu, short press the **Up/Down** buttons to select **Laser Rangefinder** .
2. Short press the **Menu**  button to enter the submenu.



## LRF > LRF MARK COLOR



### Set rangefinder cursor color

1. In the LRF submenu, short press the **Up/Down** buttons to select **LRF Mark Color**.
2. Short press the **Menu**  button to enter the submenu.
3. Short press the **Up/Down** buttons to move through the color options, Blue, Green, Red, White, and Black.
4. Long press the **Menu**  button to confirm the selection and exit.



## LRF > LRF MARK BRIGHTNESS

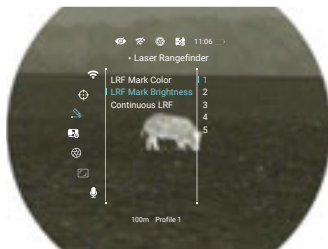

### Set the rangefinder cursor brightness

1. In the LRF submenu, short press the **Up/Down** buttons to select **LRF Mark Brightness**.
2. Short press the **Menu**  button to enter the submenu.
3. Short press the **Up/Down** buttons to toggle through brightness levels, 1 to 5.
4. Long press the **Menu**  button to confirm the selection and exit.



## LRF > CONTINUOUS LRF

### Turn continuous LRF mode on or off

1. In the LRF submenu, short press the **Up/Down** buttons to select **Continuous LRF**.
2. Short press the **Menu**  button to turn the Continuous LRF toggle ON or OFF.
3. Long press the **Menu**  button to confirm the selection and exit.



## Recoil-Activated Video (Clip-On Mode Only)





### Turn recoil activated video (RAV) on or off and set recoil sensitivity

1. In the main menu, short press the **Up/Down** buttons to select **Recoil-Activated Video**  to enter the RAV submenu.



## RAV > TOGGLE

### Turn RAV on or off

1. In the RAV submenu, short press the **Menu**  button a second time to turn the RAV toggle ON or OFF.
  - a. The RAV status, on  or off , appears in the status bar.
  - b. When recoil activated video is turned on, the MATE Series records 10 seconds before each shot and 20 seconds after the shot.
  - c. A slow-motion video of the bullet impact is also captured.
2. Long press the **Menu**  button to confirm the selection and exit.

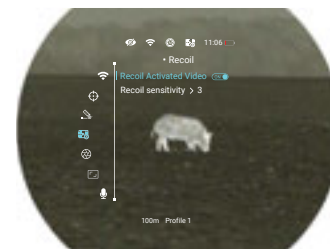

## RAV > RECOIL SENSITIVITY

### To adjust the recoil sensitivity

1. In the RAV submenu, short press the **Up/Down buttons** to move to **Recoil Sensitivity**.
2. Short press the **Menu (M) button** to enter the submenu.
3. Short press the **Up/Down buttons** to toggle through the sensitivity levels, 1 to 6.
  - a. **Smaller values:** It is easier to trigger the recoil recording, which is suitable for a smaller bullet.
  - b. **Larger values:** It is more difficult to trigger the recoil recording, which is suitable for a larger bullet.
4. Long press the **Menu (M) button** to confirm the selection and exit.

### NOTES:

- When multiple shots are taken within the same 30-second period, only one video is recorded.
- When recoil activated video recording is turned on, standard video recording is unavailable.

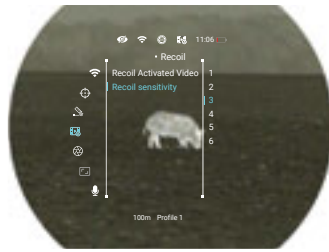

## Calibration

### Set the non-uniformity correction (NUC) mode to automatic or manual

1. In the main menu, short press the **Up/Down buttons** to select **Calibration**.
2. Short press the **Menu (M) button** to enter the submenu.
3. Short press the **Up/Down buttons** to move through the submenu options, NUC modes: A (automatic), M (manual), and Background (B). The selected NUC mode, A, M, or B appears in the status bar.
4. Long press the **Menu (M) button** to confirm the selection and exit.

**NOTE:** When performing a background NUC, you need to close the lens cap according to the prompts.

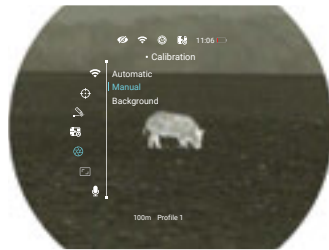

## Magic Zoom

### Calibrate the Magic Zoom

When Magic Zoom is not connected, the Magic Zoom menu option icon is disabled (grayed out). When the Magic Zoom is successfully connected, the menu option icon is enabled and is available for calibration.

See page 27 for calibration instructions.



## Microphone

### Turn the microphone on or off

1. In the main menu, short press the **Up/Down buttons** to select **Microphone**.
2. Short press the **Menu (M) button** to turn the microphone ON or OFF.
3. Long press the **Menu (M) button** to confirm the selection and exit.



## Standby

### Turn auto standby on or off

When turned on, the device automatically enters standby when no user is detected. When the built-in proximity sensor detects a face, the device automatically exits standby mode.

1. In the main menu, short press the **Up/Down buttons** to select **Standby**.
2. Short press the **Menu (M) button** to turn auto standby ON or OFF.
3. Long press the **Menu (M) button** to confirm the selection and exit.



## NOTES:





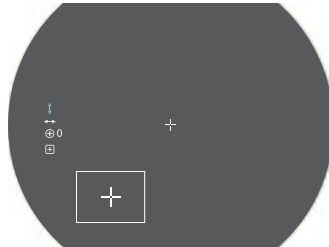
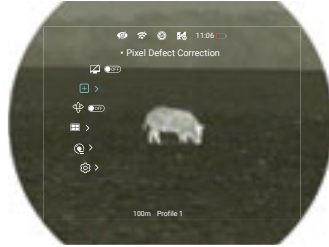

- When automatic standby is turned **ON**:
  - The MATE Series automatically enters standby mode if the vertical tilt angle exceeds 70° or the horizontal tilt angle exceeds 30°.
  - The MATE Series will not enter standby mode while it is in a level (horizontal) position.
- When auto standby is turned **OFF**, the MATE Series will operate until the battery runs out.

## Pixel Defect Correction



### Select and correct defective pixels

Defective pixels are pixels that do not change correctly compared to the other image pixels—they are either brighter or darker than surrounding pixels. The MATE Series has a tool that corrects defective pixels on the sensor using its internal software.



- In the main menu, short press the **Up/Down buttons** to select the **Pixel Defect Correction **.
- Short press the **Menu ** button to enter the defective pixel correction interface.
- The interface has the following features:
  - Cursor:** The pixel cursor appears in the center of the screen. Move the cursor to the position of the defective pixel.
  - PIP Window:** Shows a close-up view of the cursor location.
  - Y-Axis ** Icon: Select to move the pixel cursor vertically.
  - X-Axis ** Icon: Select to move the pixel cursor horizontally.
  - Add ** Icon: Select to add a defective pixel to the "to be corrected" list. Shows the number of defective pixels in the list.
  - Automatic Pixel Correction ** Icon: Select to automatically correct all defective pixels.

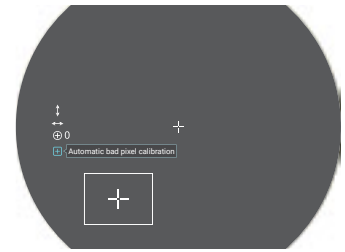

## To auto-correct defective pixels:

- Short press the **Up/Down buttons** to move to the automatic pixel correction  icon.
- Short press the **Menu ** button to correct all defective pixels automatically. The message "Calibrating in Progress" will show on the screen.



**NOTE:** If the algorithm fails to locate all defective pixels, it may be necessary to manually correct additional pixels.

## To manually select and correct defective pixels:

- Short press the **Up/Down buttons** to move between **X** and **Y**. The cursor location is marked by a blue icon.
- Short press the **Menu ** button to select **X** or **Y**. The selected axis begins flashing.
- Move the cursor along the selected axis to the location of the defective pixel:
  - Use the **Up button** to move in the positive direction: X= Right and Y= Up.
  - Use the **Down button** to move in the negative direction: X= Left and Y= Down.
  - Short press the **Up/Down buttons** to move the cursor in the corresponding direction by 1 pixel; long press to move 10 pixels.
- Short press the **Menu ** button to save the position for the selected axis and deselect it. When deselected, the axis stops flashing.
- Repeat steps 1 to 4 to move the cursor along the second axis as needed.

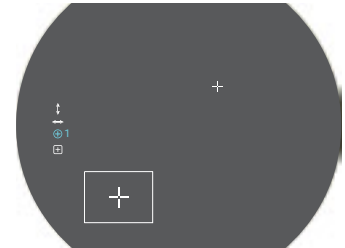
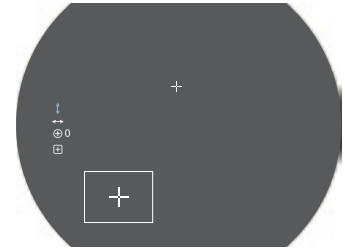

6. Add the pixel to the “to be corrected” list:

- a. With the pixel cursor position saved and marking the location of the defective pixel, short press the **Up/Down buttons** to move to the add **+** icon.
- b. Short press the **Menu (M)** button to add the pixel to the list.
- c. **⊕ 0** changes to **⊕ 1** to indicate that one pixel has been added to the correction list.
- d. If the defective pixel has been added in error, short press the **Menu (M)** button a second time from the same X/Y coordinates (do not move the cursor) to remove the pixel from the “to be corrected” list.
- e. Repeat the above steps to add additional defective pixels, as needed.

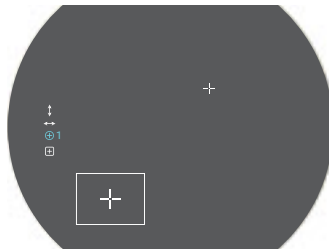

7. When all defective pixels have been added to the list, long press the **Menu (M)** button to confirm changes.

8. A popup window shows the message “Do you want to keep these settings?” and two options, Yes and No. Yes is selected by default.

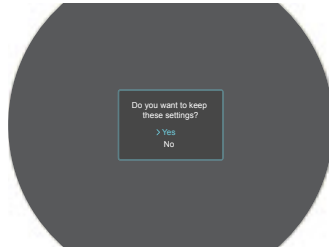

9. Short press the **Menu (M)** button to select **Yes** to correct the saved list of defective pixels and exit to the home screen.
10. Short press the **Up/Down buttons** to move to **No**, and short press the **Menu (M)** button to exit to the main menu without correcting any defective pixels.

## Motion Sensor

### Turn the motion sensor on or off

1. In the main menu, short press the **Up/Down buttons** to select **Motion Sensor** .
2. Short press the **Menu (M)** button to toggle the motion sensor ON or OFF. When on, the tilt angle appears at the bottom of the screen and the pitch angle appears on the right side of the screen.
3. Long press the **Menu (M)** button to return to the home screen.

**NOTE:** The tilt and pitch are not shown when the menu is open.





## Gallery

### View photos and videos saved to the device

1. In the main menu, short press the **Up/Down buttons** to select **Gallery** .
2. Short press the **Menu (M)** button to enter the submenu.
3. Short press the **Up/Down buttons** to move through the multimedia folders and files.
  - a. Folders are named by date in YYYYMMDD format, and images and videos are named in HHMMSS format.
  - b. Files are ordered from newest to oldest.
  - c. As the cursor moves up and down through the files in a folder, a thumbnail of the selected file appears on the right side of the screen.
4. Short press the **Menu (M)** button to enter a folder or view an image or video file in full screen.





- a. Short press the **Menu**  button to play or pause full-screen video files.
  - b. Short press the **Up/Down** buttons to rewind and fast forward.
5. Short press the **Power**  button to return to the previous menu level.
  6. Long press the **Menu**  button to return to the home screen.



## Eyepiece

### Set the eyepiece mode

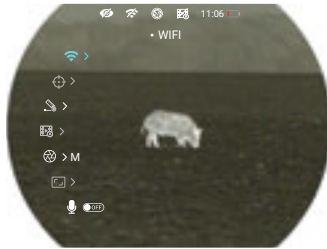
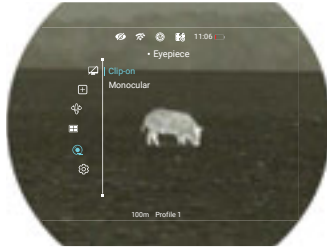

1. In the main menu, short press the **Up/Down** buttons to select **Eyepiece** .
2. Short press the **Menu**  button to enter the submenu.
3. Short press the **Up/Down** buttons to move through the submenu options:
  - a. **Clip-on**: Select when using the MATE Series on a day scope. When selected, the size of the UI icons decreases, and clip-on only menu items (zeroing and recoil activated video) become available.
  - b. **Monocular**: Select when using the MATE Series as a handheld imager. When selected, the size of the UI icons increases, and clip-on only menu items become unavailable.
4. Long press the **Menu**  button to return to the home screen.



**NOTE:** Ensure the MATE Series is in clip-on mode before installing it on a day scope.

## Settings Menu





### Adjust the general settings

1. Long press the **Menu**  button to enter the main menu.
2. Short press the **Up/Down** buttons to select **Settings** .
3. Short press the **Menu**  button to enter the submenu.



## SETTINGS > DATE

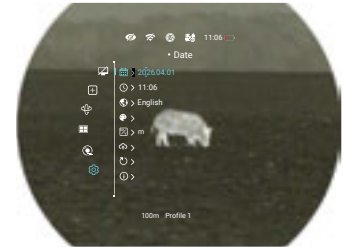

### Set the date

1. In the settings submenu, short press the **Up/Down** buttons to select **Date** .
2. Short press the **Menu**  button to edit the date, shown in YYYY.MM.DD format. A blue arrow appears above and below the year digit.
3. Short press the **Up/Down** buttons to select the correct value for each digit (year, month, and day).
4. Short press the **Menu**  button to switch between digits. The two arrows move to indicate the selected digit.
5. Long press the **Menu**  button to save the date and return to the home screen.



## SETTINGS > TIME

### Set the time

1. In the settings submenu, short press the **Up/Down** buttons to select **Time** .
2. Short press the **Menu**  button to edit the time, shown in 24-hour format, HH:MM. A blue arrow appears above and below the hour digit.
3. Short press the **Up/Down** buttons to select the correct value for each digit (hour and minute).
4. Short press the **Menu**  button to switch between digits. The two arrows move to indicate the selected digit.



5. Long press the **Menu** **M** button to save the time and return to the home screen. The set time appears in the status bar.

## SETTINGS > LANGUAGES

### Select the language

1. In the settings submenu, short press the **Up/Down** buttons to select **Languages** .
2. Short press the **Menu** **M** button to enter the submenu.
3. Short press the **Up/Down** buttons to move through the language options.
4. Long press the **Menu** **M** button to confirm the selection and exit.

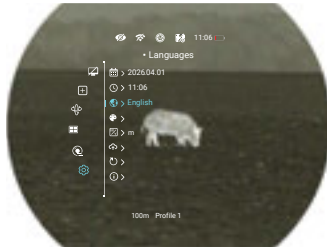

## SETTINGS > CUSTOM PALETTES

### Customize the color palettes that appear in the quick menu, so that only frequently used colors appear

1. In the settings submenu, short press the **Up/Down** buttons to select **Custom Palettes** .
2. Short press the **Menu** **M** button to enter the submenu.
3. Short press the **Up/Down** buttons to move through the toggles for the available color palettes: White Hot, Black Hot, Red Hot, Rainbow, Viridian, Crimson, and Violet.
4. Short press the **Menu** **M** button to turn each color palette toggle ON or OFF.
5. Long press the **Menu** **M** button to confirm the selection and exit.

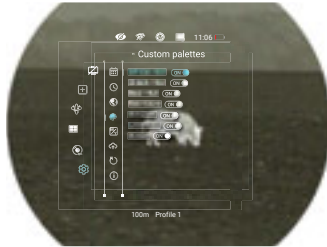

## SETTINGS > UNIT

### Select the units of measurement

1. In the settings submenu, short press the **Up/Down** buttons to select **Unit** .
2. Short press the **Menu** **M** button to enter the submenu.
3. Short press the **Up/Down** buttons to move through the options, Meters or Yards. The LRF and zeroing distance will be set to the selected units.
4. Long press the **Menu** **M** button to confirm the selection and exit.



## SETTINGS > FIRMWARE UPDATE

### Update the firmware

**NOTE:** A firmware update can also be performed in the NOCPIX App.

1. In the settings submenu, short press the **Up/Down** buttons to select **Firmware Update**  to check for available firmware updates.



## SETTINGS > FACTORY RESET

### Restore factory default settings

1. In the settings submenu, short press the **Up/Down** buttons to select **Factory Reset** .
2. Short press the **Menu** **M** button to enter the submenu.
3. Two options, Yes and No, appear; **Yes** restores factory settings and **No** cancels the operation.
4. Short press the **Menu** **M** button to select **No** to cancel the factory reset and return to the submenu; **OR**
5. Short press the **Up/Down** buttons to select **Yes**, and short press the **Menu** **M** button to confirm the factory reset. Factory settings will be restored and the MATE Series will reboot automatically after a short pause; do not press any buttons during this time.



## FACTORY RESET NOTES:

- A factory reset cannot be undone.
- The settings listed below will be reset to the factory defaults:
  - Palette: White Hot
  - Screen Brightness: 3
  - Image Contrast: 3
  - Image Sharpness: 3
  - Ultra-Clear: Off
  - Image Hue: C (cool)
  - Wi-Fi: Off
  - N-Link: Off
  - LRF Cursor:
    - Color: Green
    - Brightness: 5
  - Continuous LRF: On
  - RAV: On
  - Recoil Sensitivity: 3
  - Calibration: M (manual)
  - Microphone: On
  - Auto Standby: On
  - Motion Sensor: Off
  - Eyepiece Mode: Clip-on
  - Language: English
  - Unit: Meters
  - Wi-Fi Password: 12345678
  - Wi-Fi SSID: MATE ULTRA S60R\_XXXXXXX

## SETTINGS > INFO ⓘ

### Show device information

1. In the settings submenu, short press the **Up/Down** buttons to select **Info** ⓘ.
2. Short press the **Menu** **M** button to enter the submenu.
3. The following device info is displayed: the model, part and serial numbers; GUI, SYS, BOOT, and FPGA versions; and the FCC ID.
4. Long press the **Menu** **M** button to return to the home screen.



## 20. Basic Inspection

It is recommended to carry out a technical inspection before each use. Please check the following:

- The imager's appearance: there should be no cracks in the body or visible damage.
- The condition of the objective lens and eyepiece: there should be no cracks, greasy spots, dirt, or other deposits on the lens.
- The rechargeable battery should be fully charged.
- The control buttons should be in working order.

## 21. Basic Maintenance

Always replace the objective lens cap after use to avoid damaging or scratching the lens. Never touch the lens directly; oil from your skin can damage the lens coating and surface.

Basic maintenance should be carried out at least twice a year and includes the following steps:

- Wipe the surface of the external metal and plastic components with a clean, dry cotton cloth. Do not use chemical, corrosive, or abrasive cleaners. Canned air may also be used to clean the external components.
- Clean the electric contacts and battery slots on the imager using a non-greasy organic solvent.
- Check the lens and eyepiece. If necessary, remove any dirt or sand from the optics; a non-contact cleaning method is preferred.
- Cleaning the exterior of the lens should only be done with the included microfiber lens cloth or a similar product. Only clean the lens when it is visibly soiled. Frequent wiping or cleaning can degrade the anti-reflective lens coating.

## 22. Warranty

At iRayUSA we're first and foremost hunters and users of our products and we understand that failure isn't an option. We also understand that having to wait extended periods for repair isn't something that a customer should have to put up with when something does go wrong. During your published warranty period, iRayUSA will repair or replace, at its discretion, any optic that becomes defective during normal use. Additionally, if we cannot fix your optic in less than one week, we will offer to replace it with a replacement product in like or better condition. If you would rather wait for your specific optic to be repaired, we can handle that too.

We know you've never seen this from a thermal manufacturer and neither have we; that's why we started iRayUSA.

Our warranty follows the product and is not tied to the original owner. The warranty period is tied to the date of sale to the dealer. This warranty only covers normal use and does not cover cosmetic damage, normal wear, intentional damage, theft, loss, any act of God, or a condition caused by use other than intended. Any product that is modified, opened, or tampered with will void any warranty coverage. Any serial number damage or alteration on the product will be considered a modification. Be sure to register your MATE Series imager at [irayusa.com/register](http://irayusa.com/register).

To return a product for repair:

1. Go to [irayusa.com/warranty](http://irayusa.com/warranty) and click the **Request an RMA button** to request an RMA number. Returns will not be accepted without an RMA.
2. The customer is responsible for shipping the product to iRayUSA, per the instructions included with the RMA. iRayUSA will return the product at no cost.

#### WARRANTY NOTES:

- The one-week timeline starts from the time of receipt of the product at iRayUSA.
- iRayUSA is not liable for any damages or loss incurred when shipping to iRayUSA.
- This warranty gives you specific legal rights, and you may also have other rights which vary from state to state.

Please give us a call at **800-769-7125**, visit [irayusa.com/warranty](http://irayusa.com/warranty), or email [info@irayusa.com](mailto:info@irayusa.com) with any questions.

## 23. FCC Statement

### FCC ID: 2BHFB-4071-00

This device complies with part 15 of the FCC Rules. Operation is subject to the following two conditions: (1) This device may not cause harmful interference, and (2) this device must accept any interference received, including interference that may cause undesired operation.

**CAUTION:** Changes or modifications not expressly approved by iRayUSA could void the user's authority to operate the equipment.

**NOTE:** This equipment has been tested and found to comply with the limits for a Class B digital device, pursuant to part 15 of the FCC Rules. These limits are designed to provide reasonable protection against harmful interference in a residential installation. This equipment generates, uses and can radiate radio frequency energy and, if not installed and used in accordance with the instructions, may cause harmful interference to radio communications. However, there is no guarantee that interference will not occur in a particular installation. If this equipment does cause harmful interference to radio or television reception, which can be determined by turning the equipment off and on, the user is encouraged to try to correct the interference by one or more of the following measures:

- Reorient or relocate the receiving antenna.
- Increase the separation between the equipment and receiver.
- Connect the equipment into an outlet on a circuit different from that to which the receiver is connected.
- Consult the dealer or an experienced radio/TV technician for help.

This device was tested for typical body-supported operations and use. To comply with RF exposure requirements, a minimum separation distance of 0.5cm must be maintained between the user's body and the handset, including the antenna. Third-party belt-clips, holsters, and similar accessories used by this device should not contain any metallic components. Body accessories that do not meet these requirements may not comply with RF exposure requirements and should be avoided. Use only the supplied or an approved antenna.

## 24. General Troubleshooting

The troubleshooting table on page 40 lists issues that may occur when operating the MATE Series. Carry out the recommended troubleshooting steps in the order shown in the table. Please contact iRayUSA at 800-769-7125 or [irayusa.com/support](http://irayusa.com/support) or an authorized vendor for assistance before attempting to perform any modifications or repairs beyond the scope of the troubleshooting procedures in this manual. Unauthorized repairs or modifications will void your warranty.



ISSUE	POSSIBLE CAUSES
The MATE Series will not turn on.	The battery is very low or has fully discharged.
The MATE Series can not connect to a computer or external power supply.	External power supply has completely discharged.
	Computer is turned off. USB-C cable is damaged.
The MATE Series can not connect to the mobile device (smartphone or tablet).	Wi-Fi is not turned on.
	Wrong Wi-Fi password entered.
	Too many Wi-Fi signals nearby, which may cause interference.
Wi-Fi signal is lost or interrupted.	The device is out of range of a strong Wi-Fi signal, or there are obstacles (such as concrete walls) between the device and the signal.
The image is blurry, the background is uneven, or vertical lines or artifacts are present.	Non-uniformity correction is required.
The image is too dark.	Image brightness level is too low.
The GUI is clear, but the image is blurry.	The lens is not focused.
	There is dust or ice on the exterior lens surface.
	There is condensation on the interior or exterior lens surface.
Observed target disappears.	Observing the target through glass.
The MATE Series will not focus.	Image settings are not optimal for the current environmental conditions or the object being observed.
Image quality is low or the detection range is reduced.	Environmental conditions, such as snow, rain, humidity, and fog.
When the MATE Series is used in low-temperature conditions, the image quality of the surroundings is worse than in warm-temperature conditions.	Environmental conditions.

TROUBLESHOOTING STEPS
Charge the battery.
Check the external power supply and charge it if necessary.
Power on the computer.
Replace the cable.
Turn on the Wi-Fi in the main menu. See <b>Main Menu &gt; Wi-Fi</b> on page 34.
On the mobile device, go to <b>Settings &gt; Wi-Fi</b> and enter the correct password. The default password is 12345678. See <b>Main Menu &gt; Wi-Fi</b> on page 34.
Move the MATE Series and mobile device to an area with no or fewer Wi-Fi signals.
<ul style="list-style-type: none"> <li>Try again when the Wi-Fi signal is stable.</li> <li>Move the MATE Series closer to the Wi-Fi signal.</li> </ul>
Perform a non-uniformity correction. See <b>Non-uniformity Correction</b> on page 20.
Adjust the image brightness or contrast. See <b>Using the Quick Menu</b> on page 18.
<ul style="list-style-type: none"> <li>Adjust the focus on the target by rotating the objective focus knob (3).</li> <li>Adjust the image sharpness. See <b>Quick Menu &gt; Image Sharpness</b> on page 31.</li> </ul>
<ul style="list-style-type: none"> <li>Wipe the external optical surface with the included microfiber lens cloth.</li> </ul>
<ul style="list-style-type: none"> <li>Wipe the external optical surface with the included microfiber lens cloth.</li> <li>Leave the imager in a warm, dry environment for at least 4 hours to allow it to dry.</li> </ul>
Remove any glass windows from the field of view.
<ul style="list-style-type: none"> <li>Check the external surface of the lens and eyepiece and, where necessary, wipe away any dust, condensation, frost, etc.</li> <li>In cold weather, use anti-fogging coatings, such as those made for eyeglasses.</li> <li>Adjust the focus on the target by rotating the objective focus knob (3).</li> <li>Adjust the image sharpness, contrast, or Brightness. See <b>Quick Menu &gt; Image Sharpness/Contrast/Brightness</b> on page 31.</li> <li>Adjust the image and device settings. See <b>Quick Start Guide</b> on page 7.</li> <li>Turn on Ultra-Clear mode. See <b>Quick Menu &gt; Ultra-Clear</b> on page 31.</li> </ul>
Turn on Ultra-Clear mode. See <b>Quick Menu &gt; Ultra-Clear</b> on page 31.
In warm-temperature conditions, objects being observed (surroundings and background) heat up differently because of thermal conductivity, thereby generating a high-temperature contrast. Accordingly, image quality produced by the imager will be higher. In low-temperature conditions, the background will cool down to roughly the same temperature, and thus the temperature contrast is substantially reduced and image detail can go down as there is less contrast in the scene. This is a normal function of a thermal imager and is no indicator of actual detector performance.



2601 State Hwy 121, Bldg 3, Ste 306  
Lewisville, TX 75056  
800-769-7125 | 682-499-0047  
[info@irayusa.com](mailto:info@irayusa.com)

A26C20CT