

# User's Manual

INFIRAY OUTDOOR

# RICO PRO

Rugged Infrared Compact Optic



## WARNING! ITAR REQUIREMENTS

These products may be subject to export and foreign trade control laws of the United States and may not be exported without prior approval of the U.S. Department of State. Learn more at [irayusa.com/ITAR](http://irayusa.com/ITAR).

### FCC ID: 2AYGT-RICO

This device complies with part 15 of the FCC Rules. Operation is subject to the following two conditions: (1) This device may not cause harmful interference, and (2) this device must accept any interference received, including interference that may cause undesired operation.

**CAUTION:** Changes or modifications not expressly approved by IRayUSA could void the user's authority to operate the equipment.

**NOTE:** This equipment has been tested and found to comply with the limits for a Class B digital device, pursuant to part 15 of the FCC Rules. These limits are designed to provide reasonable protection against harmful interference in a residential installation. This equipment generates, uses and can radiate radio frequency energy and, if not installed and used in accordance with the instructions, may cause harmful interference to radio communications. However, there is no guarantee that interference will not occur in a particular installation. If this equipment does cause harmful interference to radio or television reception, which can be determined by turning the equipment off and on, the user is encouraged to try to correct the interference by one or more of the following measures:

- Reorient or relocate the receiving antenna.
- Increase the separation between the equipment and receiver.
- Connect the equipment into an outlet on a circuit different from that to which the receiver is connected.
- Consult the dealer or an experienced radio/TV technician for help.

This device was tested for typical body-supported operations and use. To comply with RF exposure requirements, a minimum separation distance of 0.5cm must be maintained between the user's body and the handset, including the antenna. Third-party belt-clips, holsters, and similar accessories used by this device should not contain any metallic components. Body accessories that do not meet these requirements may not comply with RF exposure requirements and should be avoided. Use only the supplied or an approved antenna.

## TABLE OF CONTENTS

1. Overview .....	2
2. Features .....	2
3. Tech Specs .....	3
4. Accessories .....	4
5. Components and Controls .....	5
6. Description of Control Buttons & Shortcuts ...	6
7. Quick Start Guide .....	8
8. Charging the Battery Pack .....	10
9. Installing the Battery Pack.....	11
10. Removing the Battery Pack.....	12
11. Battery Safety Warnings .....	12
12. External Power Supply .....	13
13. Mounting the RICO PRO.....	13
14. Operating Instructions .....	15
15. Zeroing the RICO PRO .....	20
16. Non-Uniformity Correction.....	21
17. Photography and Video Recording .....	22
18. Accessing Internal Memory.....	24
19. Using App.....	24
20. Video Output.....	25
21. Digital Zoom .....	25
22. Picture in Picture (PIP).....	26
23. Ultra-Clear Mode.....	26
24. Main Menu Options and Descriptions.....	26
25. Basic Inspection .....	44
26. Basic Maintenance .....	44
27. Warranty.....	44
28. General Troubleshooting .....	45
30. Notes .....	48

## 1. OVERVIEW

The InfiRay Outdoor RICO PRO was built to do three things: make the best image possible, be easy to use and be the most advanced dual field-of-view (FOV) thermal weapon sight available to the commercial market. InfiRay Outdoor's patented dual FOV objective lens allows users to seamlessly switch between a wide FOV for detection and a narrow FOV for target identification. Unmatched image quality, paired with an intuitive and easy-to-use interface, HD display, 6-hour runtime, aluminum alloy housing, and 32GB of internal memory, gives you all the tools you need to take your hunt to the next level.

## 2. FEATURES

- 12  $\mu\text{m}$  high-performance thermal detector
- High image quality
- Aluminum alloy housing
- Adjustable 25/50mm focal length
- Maximum detection range 2400 yards
- Quick-change rechargeable battery pack
- HD 1024 $\times$ 768 AMOLED display
- High frame frequency: 50hz
- Compatible with ILR-1000 Laser Rangefinder Module
- Multiple zero profiles and ranges
- Digital Zoom:  $\times 1/\times 2/\times 3/\times 4$
- Built-in 32 GB storage to support image capture and video recording
- Built-in Wi-Fi module
- Mobile device App compatible
- Built-in digital compass and motion sensor
- Multiple reticle types and color options
- Custom reticle available for purchase
- Ultra-Clear mode for advanced image detail
- Picture in Picture (PIP)
- User-friendly interface
- Pixel calibration functions

## 3. TECH SPECS

RICO PRO	RH50P
<b>SENSOR</b>	
Resolution	640 $\times$ 512
Pixel Size	12 $\mu\text{m}$
Frame Rate	50hz
Image Processing	MATRIX III
Core	InfiRay Micro II 640
<b>OPTICS</b>	
Objective Lens	25 mm / 50 mm
Magnification	1.5 $\times$ / 3 $\times$
Digital Zoom	4 $\times$
Field of View	17.5 $^{\circ}$ $\times$ 13.1 $^{\circ}$ / 8.8 $^{\circ}$ $\times$ 6.6 $^{\circ}$
Detection Range	2400 Yards
Display Type	AMOLED
Display Resolution	1024 $\times$ 768
Color Palettes	White Hot, Black Hot, Red Hot, Color, Highlight
Reticle Types	7 (2 Dynamic, 5 Static)
Reticle Colors	Black, White, Red, Green
Mounting System	Picatinny MIL-STD-1913 Rail
P.I.P.	Yes
Rangefinder	ILR-1000 Laser Rangefinder (Optional/Not Included)
Eye Relief	55 mm
Diopter Range	-4 to +4
<b>ELECTRONICS</b>	
Onboard Recording	Video and Image
Onboard Storage	32 GB
Wireless Connectivity	Video and Image via App.
Data/Power Connector	USB-C
Power Supply	USB-C External, IBP-1 Li-ion Battery Pack (6+ Hours)
Start Up Time	<10 Seconds, Instant from Standby
<b>PHYSICAL</b>	
Size	9.84" $\times$ 2.40" $\times$ 2.28"
Weight	29.63 Oz
<b>ENVIRONMENTAL/WARRANTY</b>	
Warranty	5 Years
Housing Material	Aluminum
Ingress Protection	IP67
Operation Temperature	-4 $^{\circ}$ F $\sim$ 122 $^{\circ}$ F
Max. Recoil	1000 g/s <sup>2</sup> (300 Win./7mm Mag)

## 4. ACCESSORIES

The RICO PRO rifle scope ships with everything you need to get out and hunt:

- 50mm Objective Lens Cap
- Standard Rubber Eyeguard
- Dual-throw Mount for RICO
- M5 Screws for Mount
- Spanner/T15 Tool
- USB-C to Analog RCA/USB Cable 36"
- IBP-1 Battery 4400 mAh
- IBC-1 Battery Charger
- USB Power Adapter
- Storage Bag
- Lens Cloth
- User Manual



Optional accessories, such as the IRAY-AC05 ILR-1000 Laser Rangefinder Module, as well as various replacement accessories, including cables and factory mounts are available for purchase. Contact 800-769-7125 or [irayusa.com/support](http://irayusa.com/support).

## 5. COMPONENTS AND CONTROLS

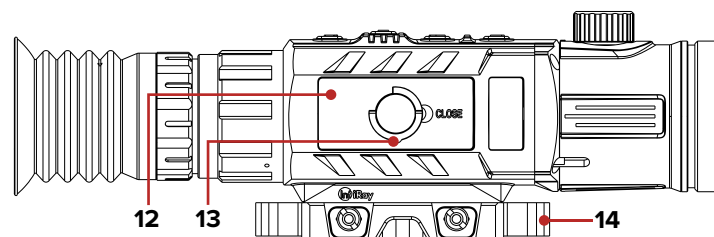
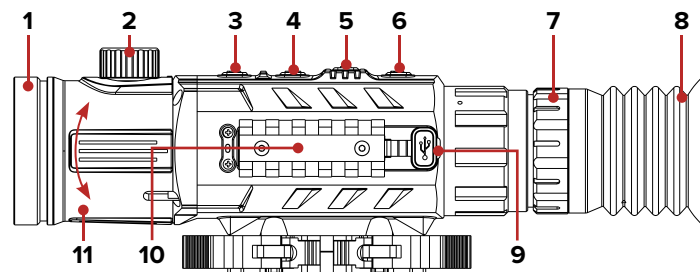



- 1 Objective Lens Cap
- 2 Objective Lens Focus Knob
- 3 Power Button
- 4 Zoom / Up Button
- 5 Menu Button
- 6 Photo / Down Button
- 7 Eyepiece / Diopter Adjustment Ring
- 8 Eyeguard
- 9 USB-C Port
- 10 Accessory Rail for ILR-1000 Laser Rangefinder Module (optional / not included)
- 11 Zoom Ring
- 12 IBP-1 Battery Pack
- 13 Battery Pack Pull-Ring
- 14 Dual-Throw Mount

## 6. DESCRIPTION OF CONTROL BUTTONS AND SHORTCUTS

Power Button 		
Current Screen, Menu, or Device Status	Short Press	Long Press
Device off	---	Power on the device
Home screen	Perform a non-uniformity correction (NUC)	Power off the device / enter standby mode
Main menu	Exit menu without saving changes	---
In standby mode	Exit standby mode	---
Defective pixel correction interface	Add or remove defective pixel from the "to be corrected" list	---
Reticle zeroing interface	Exit interface and return the reticle to the last saved zero position	---

Zoom / Up Button 		
Current Screen / Menu	Short Press	Long Press
Home screen	Adjust digital zoom	Turn PIP window on / off
Main menu / quick menu	Move cursor up	---
Defect pixel correction & reticle zeroing interfaces	Move cursor 1 pixel in the positive direction	Move cursor 10 pixels in the positive direction

Zoom + Photo Button  + 		
Current Screen / Menu	Short Press	Long Press
Reticle zeroing interface	---	Freeze image to keep reticle centered on aiming point; press again to clear frozen image



Menu Button 		
Current Screen / Menu	Short Press	Long Press
Home screen	Enter quick menu	Enter main menu
Main menu	Change menu options; enter submenu; or confirm submenu changes and return	Save and return to home screen
Quick menu	Toggle through menu options	Exit quick menu
Defective pixel correction interface	Select / deselect axis of movement (X or Y)	Correct pixel(s) and return to previous OR cancel correction and return to previous
Reticle zeroing interface	Select / deselect axis of movement (X or Y)	Save new reticle position

Photo / Down Button 		
Current Screen / Menu	Short Press	Long Press
Home screen	Take photo	Start / stop recording video
Quick menu / main menu	Move cursor down	---
Defect pixel correction & reticle zeroing interfaces	Move cursor 1 pixel in the negative direction	Move cursor 10 pixels in the negative direction

Zoom + Menu + Photo Button  +  + 		
Current Screen / Menu	Short Press	Long Press
Home screen	---	Activate / deactivate reticle (Long press for 15 seconds)

**NOTE:** Consult the manual that comes with your ILR-1000 Laser Rangefinder Module (optional/not included) for rangefinder shortcuts.

## 7. QUICK START GUIDE

### Step 1: Preparing to Use the RICO PRO

1. Compare the box contents to the accessories list and examine each for any shipping damage. See **Accessories** on page 4.
2. Check the lens to ensure there are no smudges or dirt present. Clean with the included lens cloth, if necessary.
3. Charge the battery pack (12) using the included battery pack charger (15) before using the PRO for the first time. See **Charging the Battery Pack** on page 10.
4. Insert the battery pack into the battery compartment and secure the pull ring (13). See **Installing the Battery Pack** on page 11.
5. Install the eyeguard (8).
6. Mount the PRO to the weapon. See **Mounting the RICO PRO** on page 13.

### Step 2: Turn On the PRO and Adjust the Focus

1. Open the objective lens cap (1).
2. Long press the **Power**  button for 3 seconds to power on the RICO PRO. The iRayUSA logo will appear.
3. Rotate the diopter adjustment ring (7) of the eyepiece until the interface icons are clearly visible.

**WARNING:** Do not point the objective lens toward intense energy sources, such as the sun. This may render the electronic components inoperative. The warranty does not cover damage caused by improper operation.

### Step 3: Adjust Image Settings in the Quick Menu

Short press the **Menu**  Button to enter the quick menu to adjust the following settings (see **Using the Quick Menu** on page 18):

1. Set the color palette to white hot, black hot, red hot, color, or highlight.
2. Set the display brightness level, from 1–5.
3. Set the image sharpness level, from 1–5.



### Step 4: Adjust Device Settings in the Main Menu

Long press the **Menu**  Button to enter the main menu to adjust the following settings:



1. Select the desired non-uniformity correction (NUC) mode, automatic, manual, or background. See **Main Menu > Calibration** on page 28 and **Non-Uniformity Correction** on page 21.

2. Turn on the digital compass. See **Main Menu > Compass** on page 29.
3. Turn on the motion sensor. See **Main Menu > Motion Sensor** on page 29.
4. Calibrate the digital compass. See **Main Menu > Compass Calibration** on page 39.
5. Turn on the microphone. See **Main Menu > Microphone** on page 35.
6. In the settings submenu:
  - a. Set the date and time. See **Settings Menu > Date and Settings Menu > Time** on page 40.
  - b. Select the units, meters or yards. The default is meters. See **Settings Menu > Units of Measure** on page 41.

### Step 5: Adjust Digital Zoom and PIP Settings

1. From the home screen, short press the **Zoom**  Button to toggle through the four zoom options, 1×, 2×, 3×, and 4×. The real-time amplification number appears in the status bar. See **Digital Zoom** on page 25.
2. From the home screen, long press the **Zoom**  Button to turn on the PIP window. A 2× zoomed image (2× that of the total zoom shown in the status bar) will appear at the top of the screen. See **Picture in Picture (PIP)** on page 26.

### Step 6: Set Up the Reticle and Zero the PRO

1. The reticle may be inactive when the PRO is powered on for the first time. To activate the reticle, press and hold the **Zoom** , **Menu** , and **Photo**  Buttons at the same time for 15 seconds from the home screen.
2. Set the zeroing profile to A, B, or C. See **Reticle Menu > Zeroing Profile** on page 30.
3. Set the reticle type to 1–7. See **Reticle Menu > Reticle Type** on page 31. A custom reticle is also available for purchase.
4. Set the reticle color to white, black, red, or green. See **Reticle Menu > Reticle Color** on page 31.
5. Zero the rifle scope. See **Zeroing the RICO PRO** on page 20.
  - a. Select, or customize, a preset zero distance that matches the target distance. See **Zeroing Menu > Zero Distance Submenu** on page 32.
  - b. Zero the reticle. See **Zeroing Menu > Reticle Zeroing** on page 33 for detailed reticle zeroing instructions.

## 8. CHARGING THE BATTERY PACK

The RICO PRO rifle scope comes with a long-lasting rechargeable lithium-ion battery pack, which allows for 6+ hours of operation. The IBP-1 battery pack uses a cam-locking mechanism to ensure quick and secure battery changes in the field. Fully charge the battery pack before using the RICO PRO for the first time.

### Charging with the Battery Charger

1. Insert the battery pack (12) into the battery charger (15). Align the slots (A) on the edge of the battery pack with the pins (B) on the inside of the charger.
2. Connect the small USB-C end of the data cable (16) to the USB-C port (C) on the battery charger.
3. Connect the standard USB end of the data cable to:
  - a. The included 5V–2A USB power adapter; **OR**
  - b. Any standard USB 3.0 port on a laptop or computer.

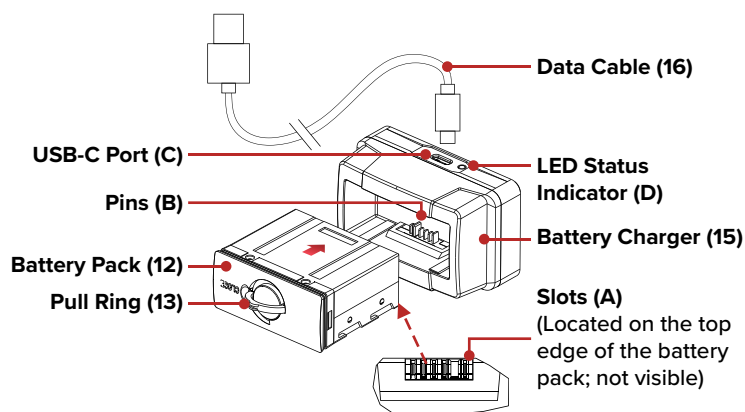

4. During charging, the LED indicator (D) on the battery charger will be solid red.
5. When fully charged, remove the battery pack from the charger.
  - a. The LED indicator will turn solid green when the battery is fully charged. Do not overcharge.



**NOTE:** When the LED indicator flashes red, the battery charger is connected to a power source but no battery pack is installed.

**WARNING:** Never use the battery charger with a USB power adapter that is greater than 5V–2A.

## Charging via the USB-C Port

1. Connect the small USB-C end of the data cable (16) to the USB-C port (9) on the side of the PRO.
2. Connect the standard USB end of the data cable to:
  - a. The included 5V–2A USB power adapter; **OR**
  - b. Any standard USB 3.0 port on a laptop or computer; **OR**
  - c. An external power supply, such as a USB power bank.

### NOTES:

- You may charge and operate the PRO at the same time.
- When the battery status icon in the status bar becomes the low battery  icon, charge the battery right away to avoid over-discharge and a reduction in battery capacity or service life.
- While charging, the battery status icon shown in the status bar will change to the charging  icon.

## 9. INSTALLING THE BATTERY PACK

1. Lift the pull-ring (13) on the battery pack (12) and rotate it clockwise 90 degrees until it is horizontal to the battery pack.
2. Position the battery pack face up with the slots (A) facing up.
3. Align the slots (A) on the top edge of the battery pack with the pins (B) on the inside of the battery compartment, then slide the battery pack into the opening.

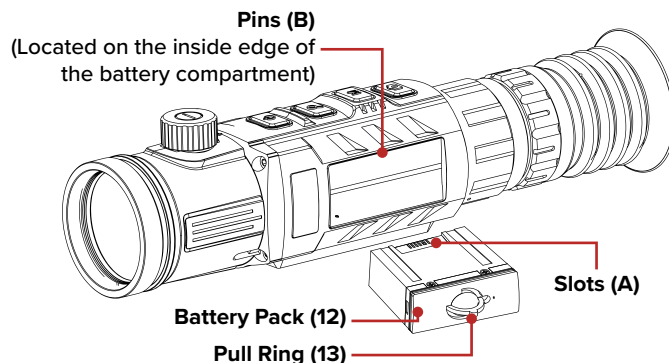

4. Firmly press the battery in to fully insert it.
5. Rotate the pull-ring counterclockwise 90 degrees to the vertical position to lock the battery pack in place.
6. Flip the pull-ring down so that it is flush with the battery pack.

**WARNING:** The PRO can only be powered by a factory-supplied IBP-1 battery pack. Using any other battery pack may cause irreparable damage to the device or cause a fire. Any damage from using an improper battery pack will not be covered by warranty.

## 10. REMOVING THE BATTERY PACK

To remove the battery pack from the RICO PRO:

1. Lift the pull-ring (13) on the battery pack (12) and rotate it clockwise 90 degrees until it is horizontal to the battery pack.
2. Pull the battery pack out.

## 11. BATTERY SAFETY WARNINGS

**WARNING:** Only use the battery charger (15) supplied with the battery pack. The use of any other charger may irreparably damage the battery pack or the charger and may cause a fire. Any damage from using an improper battery charger will not be covered by warranty.

### WARNINGS:

- Do not use a battery charger, power adapter, or USB cable that has been modified or damaged.
- Do not expose the battery to high temperatures or flames, and do not immerse in water.
- Do not leave the battery unattended while charging.
- Do not leave the battery in the charger for long periods after full charge is reached. Charging time should not exceed 24 hours.
- Keep the battery pack out of the reach of children and pets.
- The battery is equipped with short-circuit protection. However, any situation that may cause short-circuiting should be avoided.
- Do not disassemble, modify, hit, or drop the battery pack.
- Do not connect the battery to any external device with an electrical current that exceeds permitted levels.
- Do not connect an external device with a current supply that exceeds a 3.0 USB port.

To maintain optimal battery capacity and service life:

- Avoid storing a fully charged or discharged battery for long periods. Partial charging of the battery is necessary if the battery will be stored for an extended period.
- Do not charge an extremely cold battery without bringing it into a warm environment. Let the battery warm up for 45 minutes before charging.
- Charge the battery at a temperature range from 32°F to 113°F, otherwise, the service life of the battery may be reduced.
- The recommended operating temperature range is -4°F to 122°F. Avoid using the battery above the maximum or below the minimum recommended temperature range as this may decrease the battery capacity or service life.

## 12. EXTERNAL POWER SUPPLY

The RICO PRO supports the use of an external power supply, such as a 5V mobile power bank.

1. Connect the external power supply to the USB-C port (9).
2. The PRO will switch to operation from the external power supply, and the battery pack will begin slowly charging.
3. The battery status icon in the status bar will change to a charging battery  icon, with the battery color indicating the current charge level (green, yellow, red). See **Battery Status** on page 18 for additional information.
4. If the external power supply is disconnected, the PRO will automatically switch to the battery pack without powering off.

**NOTE:** Do not connect the PRO to an external device with a power supply that exceeds the 3.0 USB cable.

## 13. MOUNTING THE RICO PRO

### Installing the Dual-Throw Mount

Before using the RICO PRO, install the dual-throw mount to the three mounting holes in the base of the rifle scope.

1. Install the dual-throw mount (14) to the base of the PRO using a 3mm hex key and the M5 screws (17) supplied in the package.

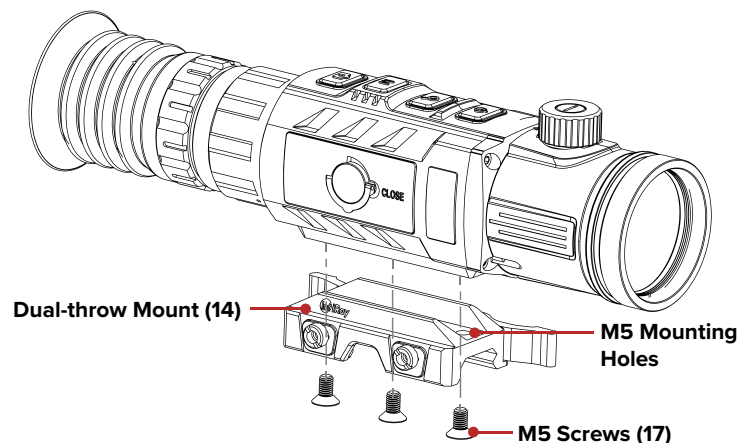

2. Install the PRO to the rifle and adjust its position so that it produces a clear image and is comfortable for the shooter.
3. When the location is suitable, remove the M5 screws one at a time and apply a small amount of blue Locktite 242 to the threads.
4. Reinsert each screw and tighten to 20 in/lbs.
5. Allow the threadlocker to dry.

**NOTE:** Please note, torque is inch pounds, NOT foot pounds. If you do not have a torque wrench, apply until snug. Do not overtighten.



When the threadlocker is dry, install the mount and rifle scope to the Picatinny rail of your rifle.

1. Press the locking button **(18)** and pull the locking lever **(18)** to open both throw levers.
2. Install the mount to the Picatinny rail.

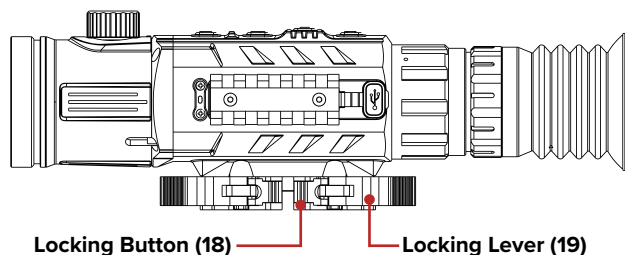

3. Turn the latches clockwise to lock the throw levers in place. You will hear the latch and locking button click.

The PRO is now ready to be zeroed. See **Zeroing the RICO PRO** on page 20 for instructions.

## Adjusting the Arm Tension

If you cannot slide the mount onto the Picatinny rail because the lever is in the open position, but the locking plate is not, OR if the mount is not tight on the rail after being locked:

1. Tighten or loosen the nuts **(20)** to adjust the throw levers until the mount is properly installed.

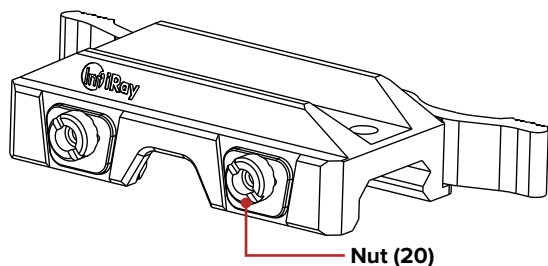

2. Move the lever to the open position. This will make the adjustment nut protrude on the opposite side of the base.
3. Turn the adjustment nut clockwise to tighten, or counterclockwise to loosen, to achieve the correct amount of tension. You should not feel any tension on the locking lever when closing until the locking lever reaches a 45-degree angle.

## 14. OPERATING INSTRUCTIONS

### WARNING!

Don't point the objective lens towards any intense energy sources, such as laser radiation or the sun. This may render the electronic components inoperative. The warranty does not cover damage caused by improper operation.

## Shortcut Buttons

The RICO PRO is operated via four control buttons. The control buttons can be used to perform shortcut operations from the home screen, as well as in the menu and full-screen interfaces. See **Description of Control Buttons and Shortcuts** on page 6 for shortcut button details.



## Power On / Starting

1. Open the objective lens cap **(1)**.
2. Long press the **Power**  button for 3 seconds to turn on the rifle scope. The iRayUSA logo will appear.

To determine the current battery charge, check the battery icon on the right side of the status bar at the top of the viewscreen. See **Battery Status** on page 18.

## Powering Off / Stopping

To power off the PRO:

1. Long press the **Power**  button. The standby screen will open, showing a 3-second countdown.
2. Continue holding the **Power**  button until the 3-second countdown completes.
3. "Data saving..." appears on the screen and the PRO will shut down automatically after saving.



**NOTE:** Releasing the **Power**  **Button** before the 3-second countdown completes will stop the shutdown process and the rifle scope will enter standby mode.





**WARNING:** If using an external power supply, do not remove the power supply when saving data, otherwise the data may not be saved.

## STANDBY MODE

Standby mode may be activated to conserve battery life.

### Manually Enter Standby Mode

The user may enter standby mode manually at any time.

- To enter standby from the home screen:
  - Short press the **Power**  and **Zoom**  **Buttons** at the same time; **OR**
  - Long press the **Power**  **Button** and release the button before the 3-second shutdown countdown finishes.
- Short press the **Power**  **Button** to exit standby.

### Set the RICO PRO to Enter Standby Mode Automatically

The rifle scope may be set to automatically enter standby mode after a specified length of inactivity.

- In the main menu, set the standby time to 2, 4, or 6 minutes. Once set, the PRO will automatically enter standby according to the set time.
- Short press the **Power**  **Button** to exit standby.

#### NOTES:

- When **2min**, **4min**, or **6min** is selected:
  - The PRO will enter standby automatically when it is tilted up or down at an angle of more than 70° or left or right at an angle of more than 30°.
  - The PRO will not enter standby mode while it is in a level firing position.
- When **off** is selected, auto standby is turned off and the rifle scope will operate until the batteries run out.
- See **Main Menu > Standby** on page 36 for instructions.

## Adjusting the Focus

### ADJUSTING THE DIOPTR/ EYEPIECE

- Rotate the eyepiece diopter adjustment ring **(7)** at the rear of the rifle scope right or left until the user interface on the screen is clear.

- Look closely to ensure all screen icons, the status bar, and the reticle appear sharp and in focus. No additional adjustments are required unless the user wishes to make changes.

#### NOTES:

- After the initial adjustment, there is no need to rotate the diopter adjustment ring **(7)** for long distances or other conditions.
- If necessary during standard use, you may rotate the objective lens focus knob **(2)** to adjust fine focus on the target object being observed. See **Focusing the Objective Lens** below.

## FOCUSING THE OBJECTIVE LENS



To adjust the focus on the target object:

- Rotate the objective lens focus knob **(2)** left or right to adjust fine focus on the target object being observed.

**NOTE:** Re-adjusting the focus will be necessary if the distance to your target changes.

## Activate / Deactivate the Reticle









The reticle may be inactive when the PRO is powered on for the first time. To activate the reticle, or to deactivate it at a later time:





- From the home screen, press and hold the **Zoom** , **Menu** , and **Photo**  **Buttons** at the same time for 15 seconds.

## Status Bar Overview

The status bar at the top of the screen shows information on the operating status of the RICO PRO:







- Color Palette:** Shows the selected color palette, white hot , black hot , red hot , color , or highlight . White hot is the default.
- Zeroing Profile & Distance:** Shows the selected zero profile, A, B, or C, and zero distance.
- Ultra-Clear Mode:** Shows the Ultra-Clear status, on  or off . Ultra-Clear mode is off by default.
- Total Magnification:** Shows the total magnification.
- Non-Uniformity Correction (NUC) Mode:** Shows the non-uniformity correction (NUC)  icon and selected mode, automatic **(A)**, manual **(M)**, or background **(B)**. A countdown timer will appear instead of the calibration mode when 5 seconds remain until an automatic NUC.
- Digital Compass:** Displays when the compass is turned on. Compass is off by default.

- 7 **Focal Length Indicator:** Shows the focal length selected, 50mm or 25mm, as well as the direction to change the focal length.
- 8 **Video Output:** Shows the video output  icon when on. Video Output is off by default.
- 9 **Microphone:** Shows the microphone status, on  or off . Microphone is off by default.
- 10 **Wi-Fi:** Shows the Wi-Fi status, on  or off . Wi-Fi is off by default.
- 11 **Time:** Shows the current time in 24-hour format.
- 12 **Battery:** Shows the current battery status.

## BATTERY STATUS



Battery icon color indicates the current battery status. The battery icon is replaced by the charging battery icon when an external power supply is connected.





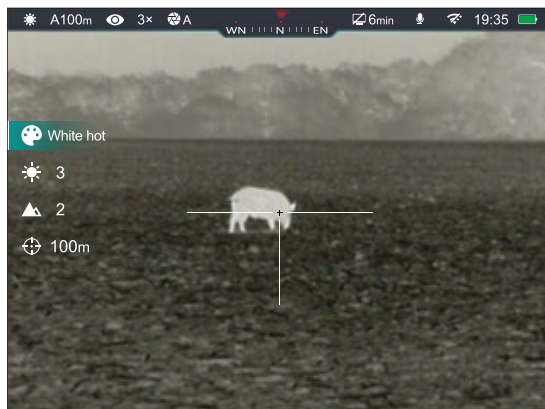



COLOR / ICON	BATTERY STATUS
Green Battery 	41% – 100%
Yellow Battery 	20% – 40%
Red Battery 	<20%; charge the battery pack right away.
Charging Battery 	The battery pack is charging; an external power supply or computer is connected via the data cable

## Using the Quick Menu

In the quick menu, the color palette, display brightness, image sharpness, and zero distance may quickly be adjusted.



1. On the home screen, short press the **Menu**  Button to enter the quick menu.
2. Press the **Up / Zoom**  Button or **Down / Photo**  Button to move between the menu options on the next page. The selected menu item is highlighted in the background.

- a.  **(Color Palette):** Short press the **Menu**  Button to set the color palette to white hot, black hot, red hot, color, or highlight.
- b.  **(Display Brightness):** Short press the **Menu**  Button to set the display brightness level, from 1–5.
- c.  **Image Sharpness:** Short press the **Menu**  Button to set the image sharpness level, from 1–5.
- d.  **Zero Distance:** Short press the **Menu**  Button to select a new zero distance within the currently selected zeroing profile. Only the zero distances in the selected profile will be available for selection. The selected zeroing profile and distance appear on the left side of the status bar.

3. Long press the **Menu**  Button to save any changes and return to the home screen.



**NOTE:** In the quick menu, if there is no user input for 5 seconds, the PRO will automatically save any changes and return to the home screen.

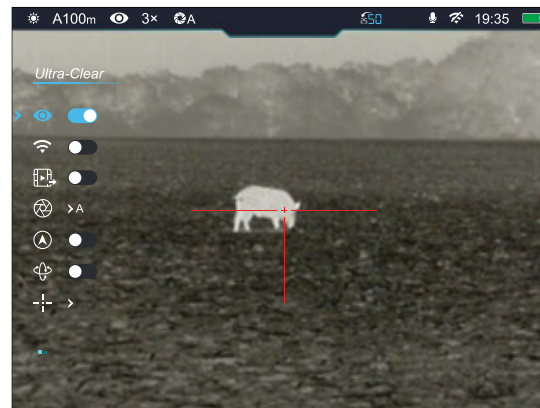

## Navigating the Main Menu

From the home screen, long press the **Menu**  Button to enter the main menu.



In all menu interfaces:





- Short press the **Up / Zoom**  Button or **Down / Photo**  Button to move up and down through the menu to switch between the main menu options.
- A blue cursor indicates the current position in the menu.
- Short press the **Menu**  Button to:
  - Change the current parameters for the selected menu option; **OR**
  - Enter the submenu; **OR**
  - Confirm submenu changes and return to the previous menu.

- Long press the **Menu**  **Button** to confirm any changes and exit to the home screen.
- Short press the **Power**  **Button** to return to the previous menu without saving.
- After 15 seconds of inactivity, the menu will automatically close and the system will return to the home screen. Changes (except changes to toggle on / off menu items, such as Ultra-Clear and Wi-Fi) are not saved automatically.
- Upon exiting from the main menu, the cursor location is stored for a single working session (until the PRO is turned off). After restarting the PRO and entering the menu, the cursor position will be at the first menu item.



## 15. ZEROING THE RICO PRO

The RICO PRO features a “freeze” zeroing method.

To zero the PRO:

1. Set a suitable target at the desired zero distance.
2. Confirm that the rifle is empty, safe, and pointed in a safe direction, with no ammunition near the weapon.
3. Adjust the image and device settings following the steps in the Quick Start Guide on page 8, if you have not done so already.
4. Set the zeroing profile to A, B, or C. See **Reticle Menu > Zeroing Profile** on page 30.
5. Based on the distance to the target you wish to zero, select a preset zero distance OR customize one of the preset zero distances to match. The PRO supports custom zeroing distances of 1 to 999 meters or 1 to 999 yards. See **Zeroing Menu > Zero Distance Submenu** on page 32.
6. Ensure a stable platform and natural shooting position is achieved behind the rifle.
7. Load ammunition, aim, and take one good shot at the target.
8. Make your rifle safe and observe the location of impact on the target.
9. If the point of impact does not match the point of aim (the center of the reticle), adjust the X/Y position of the reticle.
10. In the submenu for the selected zero distance, center the reticle on the aiming point and long press the **Zoom**  **Button** and **Photo**  **Buttons** at the same time to freeze the image. The image freeze  icon will appear below the X/Y coordinates.
11. Select the axis (X or Y) along which to move the reticle:
  - a. Short press the **Up**  or **Down**  **Button** to move between X and Y. The cursor position is indicated by a blue arrow and font.

- b. Short press the **Menu**  **Button** to select X or Y. The selected axis will flash continuously.

12. Adjust the X/Y position of the reticle until the reticle matches the point of impact.
  - a. Use the **Up**  **Button** to move in the positive direction: X= Right and Y= Up.
  - b. Use the **Down**  **Button** to move in the negative direction: X= Left and Y= Down.
  - c. Upon moving the reticle, a white dot appears on the screen, representing the original position of the reticle.
13. Long press the **Menu**  **Button** to save the reticle position.
14. Take a confirmation shot—the point of impact should now match the point of aim. If not, adjust the X/Y position of the reticle again.

For detailed Zeroing instructions, please see **Zeroing Menu > Reticle Zeroing** on page 33.

## 16. NON-UNIFORMITY CORRECTION

A non-uniformity correction (NUC) allows a thermal imager’s sensors to correct its pixels and eliminate any image defects caused by pixel drift. A NUC will be performed automatically each time the RICO PRO is powered on.

The PRO has three NUC modes, automatic (**A**), manual (**M**), and background (**B**). The selected NUC mode (**A**, **M**, or **B**) appears on the left side of the status bar. For instructions on setting the NUC mode in the main menu, see **Main Menu > Calibration** on page 28.

### Automatic Mode

In automatic mode (**A**), the PRO will perform a NUC automatically according to the internal software algorithm. There is no need to close the objective lens cap (**1**) as the PRO’s internal shutter covers the sensor.

A countdown timer will appear in the status bar instead of the calibration mode when 5 seconds remain until an automatic NUC is performed. The timer will appear only after the microbolometer temperature has stabilized—after approximately 10 minutes of continuous operation of the PRO.

**NOTE:** A manual NUC (see next page) may be performed at any time while in Automatic (**A**) mode.

## Manual Mode

In manual mode (**M**), the user independently determines the need to perform a NUC based on the quality of the observed image. It is not necessary to close the objective lens cap (**1**) during a manual NUC, as the internal shutter covers the sensor.

To perform a manual NUC while in manual mode (or automatic mode):

1. From the home screen, short press the **Power**  **Button**.
2. A manual NUC is performed instantly.

## Background Mode

In background mode (**B**), the user independently determines the need to perform a background NUC based on the quality of the observed image. A background NUC uses less power than an automatic or manual NUC because it does not use the internal shutter to cover the sensor; instead, the user must close the lens cap (**1**).

To perform a background NUC while in background mode:

1. Close the objective lens cap (**1**).
2. From the home screen, short press the **Power**  **Button**.
3. A prompt to close the lens cap (**1**) appears on the screen. The background NUC starts after about 4 seconds.

**NOTE:** If the lens is not properly covered, a temporary “image burn” will remain in the image until the next non-uniformity correction. This “image burn” is temporary and is not a defect or sign of permanent damage.

## 17. PHOTOGRAPHY AND VIDEO RECORDING

The RICO PRO is equipped with video recording and image capture. All videos and photos are automatically saved to the PRO's built-in 32 GB memory storage.

**NOTE:** Photo and video files are named with the time and date; therefore, it is recommended to set the date and time before using the photo and video functions. See **Settings Menu > Date** and **Settings Menu > Time** on page 40. Alternatively, the date and time may be synchronized in the InfiRay Outdoor App.

### Photography

To take a photo:





1. From the home screen, short press the **Photo**  **Button**.

2. The image will freeze for 0.5 seconds and the camera  icon will appear in the upper-left corner of the screen.

**NOTE:** A red warning icon  appears next to the camera icon in the upper-left corner of the screen when insufficient memory storage is available. Transfer video and image files to other storage media to free up space on the memory card.

### Video Recording

To record video:

1. Turn on the microphone in the main menu. See **Main Menu > Microphone** on page 35.
2. From the home screen, long press the **Photo**  **Button** to start a video recording.
3. When the video recording starts, the video  icon and the video recording timer, in HH:MM:SS (hour: minute: second) format, appear in the upper-left corner of the screen.
4. When recording, short press the **Photo**  **Button** to take a photo.
5. Long press the **Photo**  **Button** to stop and save the video recording.

### Video and Photography Tips

- You may enter and navigate the menu as normal during video recording. The user interface (status bar and menu) is not captured in recorded photos and video.
- Recorded photos are saved to the internal memory card in .jpg format, videos are saved in .mp4 format.
  - a. Photos are saved in IMG\_HHMMSS\_XXX.jpg format.
  - b. Videos are saved in VID\_HHMMSS.mp4 format.
  - c. HHMMSS is hour/minute/second.
  - d. XXX is a 3-digit counter number.
- The counter used for multimedia file names cannot be reset.
- If a file is deleted from the internal memory, its counter number is not taken by another file.

#### NOTES:

- The maximum duration of a recorded video file is 10 minutes. After this time, video recording will begin a new file automatically.
- The number of recorded files is limited only by the capacity of the internal memory.
- Check the available space on the internal storage card regularly and move video footage and images to other storage media to free up space on the memory card.

## 18. ACCESSING INTERNAL MEMORY

When the RICO PRO is turned on and connected to a computer via the included data cable, it is recognized by the computer as a flash memory (USB) drive. This allows the user to access the saved multimedia files and copy or delete any desired files.

To access the internal memory:

1. Turn on the PRO and connect the smaller USB-C end of the data cable to the USB-C port (9).
2. Connect the larger USB end of the data cable to your computer.
3. Double-click **My Computer** on your computer desktop.
4. Double-click to open the device named **RH50Pro**.
5. Double-click to open the device named **Internal Storage** to access the built-in memory.
  - a. The device shows the available space (in GB) remaining of the 32 GB of total memory storage.
  - b. Recorded photos and videos are separated by date into folders.
  - c. Folders are named by date, YYYYMMDD (year/month/day).
6. Select the desired files or folders to copy or delete.

## 19. USING APP

The RICO PRO can be operated using the InfiRay Outdoor App when the rifle scope is connected to a smartphone or tablet via Wi-Fi.



1. Download the App for free and install it to your smartphone or tablet:
  - a. Scan one of the QR codes above to download the InfiRay Outdoor App from the App Store or Google Play; **OR**
  - b. Download the App from any app store.
2. Connect the RICO PRO to Wi-Fi:
  - a. In the main menu, turn on Wi-Fi. See **Main Menu > Wi-Fi** on page 27 for detailed instructions.
  - b. Open the App and press the **ViewFinder**  icon on the home screen.
  - c. Click the **Connect Device WiFi** button.
  - d. On the mobile device, go to **Settings > Wi-Fi**.

- e. Select the RICO PRO from the list of Wi-Fi networks. It will appear in the list as "RH50PRO\_XXXXXX", where XXXXXX is the six-digit device serial number.
  - f. Enter the Wi-Fi password and tap the **Join button**. The default password is 12345678.
3. Operate the RICO PRO via the App:
    - a. Take real-time photos and videos, with or without audio.
    - b. View, share, download, and delete photos and videos taken via the App, which are saved to the mobile device.
    - c. Change the Wi-Fi password and SSID.
    - d. Synchronize the date and time from the mobile device.
    - e. Update the RICO PRO firmware.

**NOTE:** When a factory reset is performed, the Wi-Fi SSID and password are reset to the defaults, RH50Pro\_XXXXXX and 12345678. See **Settings Menu > Factory Reset** on page 42.

## 20. VIDEO OUTPUT

The video output function enables connectivity with an external display or recording device via analog video.

To output video:

1. In the main menu, turn on video output. See **Main Menu > Video Output** on page 28 for detailed instructions.
2. Connect the smaller USB-C end of the data cable to the USB-C port (9) on the RICO PRO.
3. Connect the RCA connector to the RCA jack on the external display or recording/display device.

## 21. DIGITAL ZOOM

The RICO PRO will quickly increase the basic magnification by enlarging the image from 1 to 4 times digitally.

To adjust the digital zoom:



1. From the home screen, short press the **Zoom**  **Button** to toggle through the digital zoom levels, 1x, 2x, 3x, or 4x. The real-time magnification is displayed in the status bar.
2. The following table lists the real-time amplification corresponding to the digital zoom level for each focal length, 25mm and 50mm.

FOCAL LENGTH	BASE MAGNIFICATION	DIGITAL ZOOM MAGNIFICATIONS			
		1x	2x	3x	4x
25mm	1.5x	1.5	3	4.5	6
50mm	3x	3	6	9	12

## 22. PICTURE IN PICTURE (PIP)

The Picture in Picture (PIP) function opens a small floating window with a magnified image view at the top of the screen. PIP allows for improved aiming while still being able to see the wide field of view in the main body of the screen.

To activate Picture in Picture mode:

1. From the home screen, long press the **Zoom**  **Button**.  
A 2× zoomed image, centered on the reticle, will appear at the top of the screen. Please note that the PIP image is 2× that of the total magnification shown on the left side of the status bar.
2. To exit PIP mode, long press the **Zoom**  **Button**.

**NOTE:** When the image in the main body of the screen is magnified via digital zoom, the PIP image will enlarge accordingly.

## 23. ULTRA-CLEAR MODE

Ultra-Clear mode improves the image quality in inclement weather conditions, such as rain, fog, high humidity, or high temperatures as these conditions all result in lower thermal contrast. Ultra-Clear mode enhances the NETD value of the thermal sensor and improves the sensor's response rate to these challenging environmental conditions.

Ultra-Clear mode provides:

- Improved image quality and clarity; images are crisper and sharper.
- Increased image detail.
- Improved recognition of observed targets.

See **Main Menu > Ultra-Clear** on the next page for instructions.

## 24. MAIN MENU OPTIONS AND DESCRIPTIONS

Menu and submenu options from top to bottom are:









- **Main Menu:** Ultra-Clear, Wi-Fi, Video Output, Calibration, Compass, Motion Sensor, Reticle, Zeroing, Microphone, Standby, Laser Calibration, Pixel Defect Correction, Compass Calibration, Settings.
  - **Reticle Menu:** Zeroing Profile, Reticle Type, Reticle Color.
  - **Zeroing Menu:** Three zero distance options.
    - **Zeroing Distance Submenu:** Reticle Zeroing, Custom Zero Distance.
  - **Settings Menu:** Date, Time, Languages, Unit, Status Bar, Factory Reset, Info.

Menu option details, descriptions, and navigation instructions are listed in order on the following pages.

## Ultra-Clear

### Turn Ultra-Clear mode on / off

When Ultra-Clear mode is turned on, the image contrast is enhanced, which is suitable for rainy, foggy, or low-contrast conditions.

1. Long press the **Menu**  **Button** to enter the main menu.
2. Short press the **Up**  or **Down**  **Button** to move through the menu to select the Ultra-Clear  menu item.
3. Short press the **Menu**  **Button** to turn Ultra-Clear on / off. Ultra-Clear is off by default.
4. The Ultra-Clear status, on  or off , appears on the left side of the status bar.
5. Long press the **Menu**  **Button** to return to the home screen.



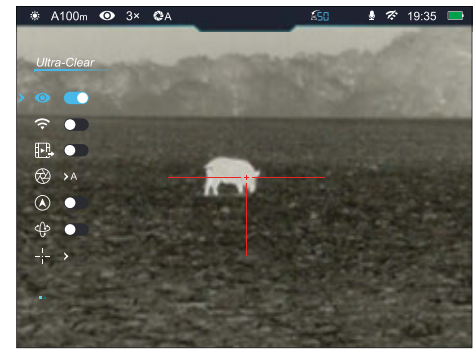





**NOTE:** When Ultra-Clear mode is turned on and off, the PRO will automatically perform a shuttered non-uniformity correction.



## Wi-Fi

### Turn Wi-Fi on / off

Turn on Wi-Fi to manipulate the PRO via the InfiRay Outdoor App.

1. Long press the **Menu**  **Button** to enter the main menu.
2. Short press the **Up**  or **Down**  **Button** to move through the menu to select the Wi-Fi  menu item.
3. Short press the **Menu**  **Button** to turn Wi-Fi on / off. Wi-Fi is off by default.
4. The Wi-Fi status, on  or off , appears on the right side of the status bar.
5. Long press the **Menu**  **Button** to return to the home screen.

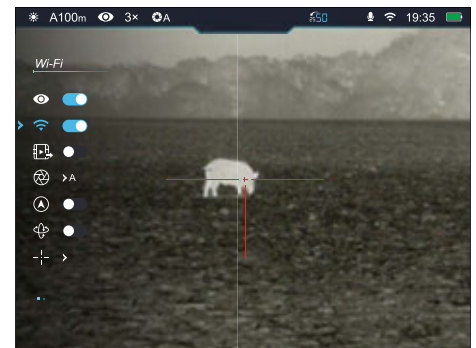





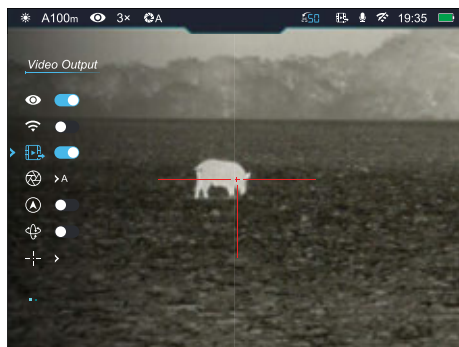

## Video Output

### Turn video output on / off

The video output function enables connectivity with an external display or recording device via analog video.











1. Long press the **Menu**  **Button** to enter the main menu.
2. Short press the **Up**  or **Down**  **Button** to move through the menu to select the video output  menu item.
3. Short press the **Menu**  **Button** to turn video output on / off. Video output is off by default.
4. When video output is on, its icon  appears on the right side of the status bar.
5. Long press the **Menu**  **Button** to return to the home screen.

## Calibration

### Select non-uniformity correction mode







The RICO PRO has three non-uniformity correction (NUC) modes: Automatic (A), Manual (M), and Background (B).



1. Long press the **Menu**  **Button** to enter the main menu.
2. Short press the **Up**  or **Down**  **Button** to move through the menu to select the calibration  menu item.
3. Short press the **Menu**  **Button** to enter the calibration submenu.
4. Short press the **Up**  or **Down**  **Button** to move through the submenu options, Automatic (A), Manual (M), and Background (B). Automatic (A) is selected by default.
5. The selected NUC mode, A, M, or B, appears on the left side of the status bar.
6. Long press the **Menu**  **Button** to confirm the selection and return to the home screen.

## Compass







### Turn the digital compass on / off

1. Long press the **Menu**  **Button** to enter the main menu.
2. Short press the **Up**  or **Down**  **Button** to move through the menu to select the compass  menu item.
3. Short press the **Menu**  **Button** to turn the digital compass on / off. The digital compass is off by default.
4. When the compass is on, it appears in the center of the status bar at the top of the screen.
5. Long press the **Menu**  **Button** to return to the home screen.



## Motion Sensor

### Turn the motion sensor on / off

1. Long press the **Menu**  **Button** to enter the main menu.
2. Short press the **Up**  or **Down**  **Button** to move through the menu to select the motion sensor  menu item.
3. Short press the **Menu**  **Button** to turn the motion sensor on / off. The motion sensor is off by default.
4. When the motion sensor is on, the tilt angle appears on the left side of the screen and the pitch angle appears on the right side of the screen.
5. Long press the **Menu**  **Button** to return to the home screen.

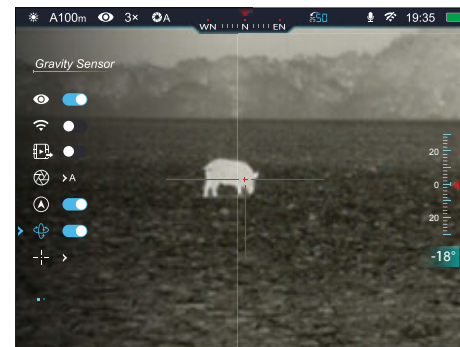





**NOTE:** The tilt angle is not shown in the figure above because it is hidden by the menu.



## Reticle





### Select the zeroing profile, reticle type, and reticle color

1. Long press the **Menu**  **Button** to enter the main menu.
2. Short press the **Up**  or **Down**  **Button** to move through the menu to select the reticle  menu item.
3. Short press the **Menu**  **Button** to enter the reticle submenu.
4. There are three submenu items: zeroing profile, reticle type, and reticle color.



## RETICLE MENU > ZEROING PROFILE





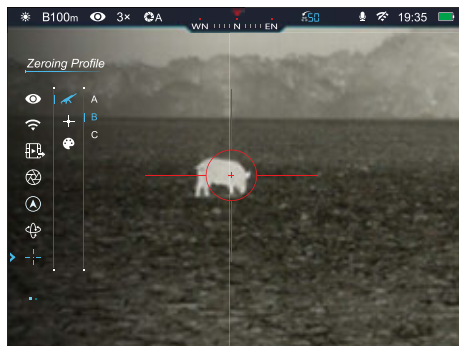

### Select the zeroing profile

1. In the reticle submenu, the zeroing profile  menu item is selected by default.
2. Short press the **Menu**  **Button** to enter the zeroing profile submenu.
3. Short press the **Up**  or **Down**  **Button** to move through zeroing profile options, A, B, C. The default is A.
4. The selected zeroing profile, A, B, or C, appears on the left side of the status bar.
5. Long press the **Menu**  **Button** to confirm the selection and return to the home screen.



## RETICLE MENU > RETICLE TYPE

### Select the reticle type

1. In the reticle submenu, short press the **Up**  or **Down**  **Button** to select the reticle type  menu item.
2. Short press the **Menu**  **Button** to enter the reticle type submenu.
3. Short press the **Up**  or **Down**  **Button** to move through reticle type options, 1–7 (see below). The default is reticle type 1. The reticle changes as the cursor moves through the reticle types. A custom reticle is available for purchase.
4. Long press the **Menu**  **Button** to confirm the selection and return to the home screen.

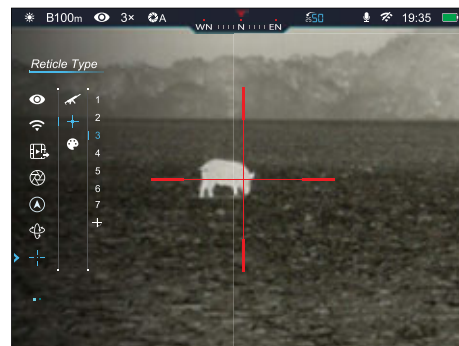



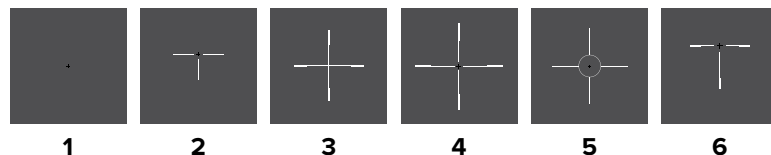



### Reticle Types



## RETICLE MENU > RETICLE COLOR

### Select the reticle color

1. In the reticle submenu, short press the **Up**  or **Down**  **Button** to select the reticle color  menu item.
2. Short press the **Menu**  **Button** to enter the reticle color submenu.
3. Short press the **Up**  or **Down**  **Button** to move through reticle color options, black, white, red, or green. The default is black. The reticle color changes as the cursor moves through the color options.
4. Long press the **Menu**  **Button** to confirm the selection and return to the home screen.







## Zeroing

### Select or customize zero distance

In the zeroing menu, you can select a preset zero distance, customize a preset zero distance, or adjust the reticle position for the selected zero distance. The PRO supports custom zero distances of 1 to 999 yards or 1 to 999 meters.







Before selecting or customizing a zero distance, you must select a zeroing profile, A, B, or C. Each zero profile has three zero distances. See **Reticle Menu > Zeroing Profile** on page 30.

1. Long press the **Menu**  **Button** to enter the main menu.
2. Short press the **Up**  or **Down**  **Button** to move through the menu to select the zeroing  menu item.
3. Short press the **Menu**  **Button** to enter the zeroing submenu. Three zero distances are shown in the submenu.

## ZEROING MENU > ZERO DISTANCE SUBMENU <sup>100m</sup>

### Select or customize a preset zero distance

1. In the zero distance submenu, short press the **Up**  or **Down**  **Button** to select a zero distance.
2. Short press the **Menu**  **Button** to enter the submenu for the selected zero distance.
3. In the submenu for the selected zero distance, you may:
  - a. Enter the reticle zeroing interface  to adjust the X/Y position of the reticle at the selected zero distance. See **Reticle Zeroing** below.
  - b. Customize the selected preset zero distance, as needed. See **Zeroing Menu > Customize Zero Distance** on page 35.











## ZEROING MENU > ZERO DISTANCE SUBMENU > RETICLE ZEROING

### Adjust the reticle position of the selected zero distance.

In the reticle zeroing interface, the X/Y position of the reticle may be adjusted to match the point of impact. Refer back to **Zeroing the RICO PRO** on page 20, if necessary.



1. In the submenu for the selected zero distance, the reticle zeroing  menu item is selected by default. Short press the **Menu**  **Button** to select and enter the reticle zeroing interface.
2. The reticle zeroing interface has the following features:
  - 1 **X**: Horizontal point of impact change (in cm or inches).
  - 2 **Y**: Vertical point of impact change (in cm or inches).
  - 3 **Freeze Icon**: Appears when the image is frozen.
  - 4 **Focal Length**: Shows the selected focal length, 25mm or 50mm.
  - 5 **Reticle**: Shows the new reticle position.
  - 6 **White Dot**: Indicates the center of the original reticle position.
3. Center the reticle on the aiming point and long press the **Zoom**  and **Photo**  **Buttons** at the same time to freeze the image. The image freeze  icon will appear below the X/Y coordinates.
4. Select the axis (X or Y) along which to move the reticle:
  - a. Short press the **Up**  or **Down**  **Button** to move between X and Y. The cursor position is indicated by a blue arrow and blue font.
  - b. Short press the **Menu**  **Button** to select or deselect an axis (X or Y). The selected axis will flash continuously. When deselected, the axis will stop flashing.



- Adjust the X/Y position of the reticle until the reticle matches the point of impact.

a. **X** (horizontal) is the windage and **Y** (vertical) is the elevation.

b. Upon moving the reticle, a white dot appears on the screen, representing the original position of the reticle.



c. Use the **Up** **Button**

to move in the positive direction: X= Right and Y= Up.

d. Use the **Down** **Button** to move in the negative direction: X= Left and Y= Down.

e. Short press the **Up** or **Down** **Button** to move the reticle in the corresponding direction by 1 pixel; long press to move 10 pixels.

f. **With the 25mm focal length selected:** when adjusting your zero at a distance of 50 yards, a short press will change the impact point by 0.75" and a long press moves 7.50" as shown in the X and Y coordinate displays. At 100 yards that same short press moves 1.50" and a long press moves 15.00". At 200 yards a short press moves 3.00" and a long press moves 30.00".

g. **With the 50mm focal length selected:** when adjusting your zero at a distance of 50 yards, a short press will change the impact point by 0.38" and a long press moves 3.75". At 100 yards a short press moves 0.75" and a long press moves 7.50". At 200 yards a short press moves 1.50" and a long press moves 15.00".

h. Changing your zero distance will change the distance of the X/Y adjustments automatically. When the 50mm focal length is selected: if your selected zero distance has a correction of 1.50" at 100 yards, it will automatically double if you change the zero distance to 200 yards.

- Short press the **Menu** **Button** to save the position for the selected axis and deselect it. The axis will stop flashing.
- Move to and select the second axis and adjust the reticle position, as needed.
- Short press the **Power** **Button** to exit the interface without saving the new reticle position; **OR**
- Long press the **Menu** **Button** to save the reticle position and exit the interface. A 5-second countdown appears on the screen, followed by "Saved Successfully."

- Take a confirmation shot—the point of impact should now match the point of aim. If not, adjust the X/Y position of the reticle again.

## ZEROING MENU > ZERO DISTANCE SUBMENU > CUSTOMIZE ZERO DISTANCE

### Customize a preset zero distance

The RICO PRO supports custom zero distances of 1 to 999 yards or 1 to 999 meters.

- In the submenu for the selected zero distance, short press the **Up** or **Down** **Button** to select the zero distance customization menu item (the selected zero distance, for example, "109y", will appear instead of "000m").
- Short press the **Menu** **Button** to customize the selected preset zero distance. Blue triangle icons will appear above and below the selected digit to mark the cursor location. The left digit is selected by default.
- Short press the **Up** or **Down** **Button** to increase or decrease the value of the selected digit, from 0–9.
- Short press the **Menu** **Button** to switch between the three digits. The two triangle icons will move to indicate the selected digit.
- Long press the **Menu** **Button** to save the custom zero distance and return to the zero distance submenu.
- The new zero distance appears on the left side of the status bar.





## Microphone

### Turn the microphone on / off

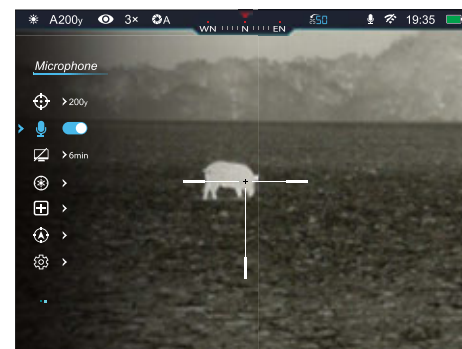
- Long press the **Menu** **Button** to enter the main menu.
- Short press the **Up** or **Down** **Button** to move through the menu to select the microphone menu item.
- Short press the **Menu** **Button** to turn the microphone on / off. The microphone is off by default.











- The microphone status, on  or off , appears on the right side of the status bar.
- Long press the **Menu**  **Button** to return to the home screen.

## Standby

### Set automatic standby status and time

To conserve battery, the PRO may be set to automatically enter standby mode after a specified length of inactivity (2, 4, or 6 minutes).



- Long press the **Menu**  **Button** to enter the main menu.
- Short press the **Up**  or **Down**  **Button** to move through the menu to select the standby  menu item.
- Short press the **Menu**  **Button** to enter the standby submenu.
- Short press the **Up**  or **Down**  **Button** to move through the standby submenu options, 2min, 4min, 6min, or off. Standby is off by default.
- Long press the **Menu**  **Button** to confirm the selection and return to the home screen.
- When 2, 4, or 6 minutes is selected, the PRO will automatically enter standby mode, after the set length of inactivity.
- Short press the **Power**  **Button** to exit standby and return to the home screen.

### NOTES:

- When **2min**, **4min**, or **6min** is selected:
  - The PRO will enter standby mode automatically when it is tilted up or down at an angle of more than 70° or left or right at an angle of more than 30°.
  - The PRO will not enter standby mode while it is in a level firing position.
- When **off** is selected, standby mode is turned off and the rifle scope will operate until the battery runs out.

## Laser Calibration







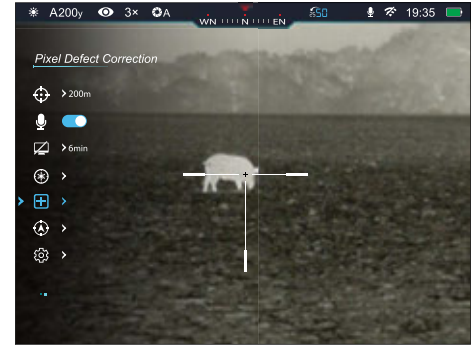

The laser calibration function of the RICO PRO requires an ILR-1000 Module (optional/not included). Please consult the documentation included with your ILR-1000 for more information on its operation.





## Pixel Defect Correction

### Select and correct defective pixels

Defective pixels are pixels that do not change correctly compared to the other image pixels—they are either brighter or darker than surrounding pixels. The RICO PRO has a tool that corrects defective pixels on the sensor using its internal software.



- Long press the **Menu**  **Button** to enter the main menu.
- Short press the **Up**  or **Down**  **Button** to move through the menu to select the pixel defect correction  menu item.
- Short press the **Menu**  **Button** to enter the defective pixel correction interface.
- The pixel correction interface has the following features:
  - Cursor:** Cursor appears in the center of the screen in place of the reticle. Move the cursor to the position of the defective pixel.
  - X:** Select to move the cursor horizontally.
  - Y:** Select to move the cursor vertically.
  - PIP Window:** The Picture in Picture window appears in the lower-left corner.
  -  00:** Shows the number of defective pixels in the “to be corrected” list.
- Select the axis (X or Y) along which to move the cursor:
  - Short press the **Up**  or **Down**  **Button** to move between **X** and **Y**. The cursor position is indicated by a blue arrow and blue font. X is selected by default.
  - Short press the **Menu**  **Button** to select an axis. The selected axis will flash continuously. When deselected, the axis will stop flashing.
- Move the cursor along the selected axis to the location of the defective pixel:

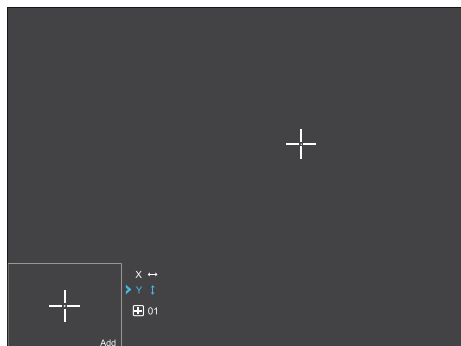

- a. Use the **Up**  **Button** to move in the positive direction: X= Right and Y= Up.
- b. Use the **Down**  **Button** to move in the negative direction: X= Left and Y= Down.
- c. Short press the **Up**  or **Down**  **Button** to move the cursor in the corresponding direction by 1 pixel; long press to move 10 pixels.

7. Short press the **Menu**  **Button** to save the position for the selected axis and deselect it. The axis will stop flashing.



8. Move to and select the second axis and adjust the cursor position, as needed.

9. With the cursor in position and the axis still selected (the axis will be flashing), short press the **Power**  **Button** to add the defective pixel to the “to be corrected” list.

- a. **Add** will briefly appear in the bottom-right corner of the PIP window.
- b.  00 will change to  01 to indicate that one pixel has been added to the correction list.

10. If the defective pixel has been added in error, short press the **Power**  **Button** a second time from the same X/Y coordinates (do not move the cursor and do not deselect the axis) to remove the pixel from the “to be corrected” list. **Del** will briefly appear in the PIP window.



11. Repeat steps 5–9 to add additional defective pixels as needed.

12. When all defective pixels have been added to the list, long press the **Menu**  **Button** to confirm changes.

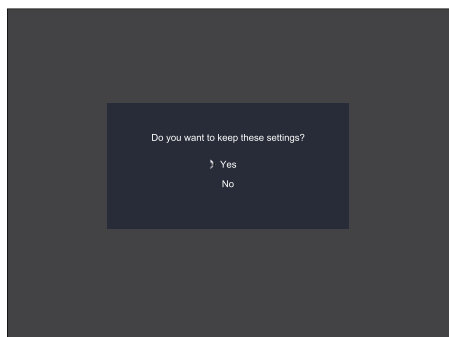
13. A popup window shows the message “Do you want to keep these settings?” and two options, Yes and No. Yes is selected by default.



14. Short press the **Menu**  **Button** to select **Yes** to correct the saved list of defective pixels and exit to the home screen. A 5-second countdown appears, followed by “Saved Successfully”; **OR**





15. Short press the **Up**  or **Down**  **Button** to select **No** and short press the **Menu**  **Button** to exit to the main menu without correcting any defective pixels.

#### NOTES:

- The PIP window and interface controls move to the upper-left corner when the cursor moves into the lower-left corner of the screen.
- After 15 seconds of inactivity, the system will automatically exit the defective pixel interface.

## Compass Calibration

### Calibrate the digital compass





1. Long press the **Menu**  **Button** to enter the main menu.
2. Short press the **Up**  or **Down**  **Button** to move through the menu to select the compass calibration  menu item.



3. Short press the **Menu**  **Button** to begin compass calibration. A triaxial coordinate icon prompt will appear on the screen.
4. Follow the icon prompt to rotate the PRO at least 360 degrees along each axis, X, Y, and Z. Rotations must be completed within the 40-second calibration time.
5. After 40 seconds, the calibration is finished and the system will automatically exit to the home screen.

## Settings

### Adjust the general settings









1. Long press the **Menu**  **Button** to enter the main menu.
2. Short press the **Up**  or **Down**  **Button** to move through the menu to select the settings  menu item.



3. Short press the **Menu**  **Button** to enter the settings submenu.
4. There are seven submenu items, date, time, language, units of measure, status auto hiding, factory reset, and info.

## SETTINGS MENU > DATE









### Set the date

1. In the settings submenu, short press the **Up**  or **Down**  **Button** to select the date  menu item.
2. Short press the **Menu**  **Button** to edit the date. Blue triangle icons will appear above and below the year digit. The date is displayed in YYYY.MM.DD format.
3. Short press the **Up**  or **Down**  **Button** to select the correct value for each digit (year, month, and day).
4. Short press the **Menu**  **Button** to switch between digits. The two triangle icons will move to indicate the selected digit.
5. Long press the **Menu**  **Button** to save the date and return to the home screen.



## SETTINGS MENU > TIME







### Set the time

1. In the settings submenu, short press the **Up**  or **Down**  **Button** to select the time  menu item.
2. Short press the **Menu**  **Button** to edit the time. Blue triangle icons will appear above and below the hour digit. The time is displayed in HH.MM, in 24-hour format.
3. Short press the **Up**  or **Down**  **Button** to select the correct value for each digit (hour and minute).
4. Short press the **Menu**  **Button** to switch between digits. The two triangle icons will move to indicate the selected digit.
5. Long press the **Menu**  **Button** to save the time and return to the home screen.
6. The time appears on the right side of the status bar.



## SETTINGS MENU > LANGUAGES







### Select the language

1. In the settings submenu, short press the **Up**  or **Down**  **Button** to select the languages  menu item.
2. Short press the **Menu**  **Button** to enter the languages submenu.
3. Short press the **Up**  or **Down**  **Button** to move through the language options, English, Russian, and Chinese. English is selected by default.
4. Long press the **Menu**  **Button** to confirm the selection and return to the home screen.



## SETTINGS MENU > UNIT

### Set the units of measurement

1. In the settings submenu, short press the **Up**  or **Down**  **Button** to select the unit  menu item.
2. Short press the **Menu**  **Button** to enter the unit submenu.
3. Short press the **Up**  or **Down**  **Button** to move through unit options, meters and yards. Meters are selected by default.
4. The selected unit, m (meters) or y (yards), will display with the selected zero profile and distance on the left side of the status bar.
5. Long press the **Menu**  **Button** to confirm the selection and return to the home screen.



## SETTINGS MENU > STATUS BAR

### Turn status bar auto hiding on / off







This function enables automatic hiding of all interface information, aside from the reticle, for unobstructed image view.

When auto-hide is turned on, after 8 seconds of inactivity, the status bar and digital compass will be automatically hidden.

Shortcut buttons and the menu are disabled until the entire interface is again displayed. Press any button to show all interface information again.







**NOTE:** When auto-hide is on and the main menu is open, the menu will hide after 15 seconds of inactivity and the rest of the interface will hide after an additional 8 seconds.





1. In the settings submenu, short press the **Up**  or **Down**  **Button** to select the status bar  menu item.
2. Short press the **Menu**  **Button** to enter the status bar submenu.
3. Short press the **Up**  or **Down**  **Button** to move through status bar options, hide and show. Hide is selected by default.
4. Long press the **Menu**  **Button** to confirm the selection and return to the home screen.

## SETTINGS MENU > FACTORY RESET

### Restore factory default settings

1. In the settings submenu, short press the **Up**  or **Down**  **Button** to select the factory reset  menu item.
2. Short press the **Menu**  **Button** to enter the factory reset submenu.
3. Two options, Yes and No, appear; Yes will restore factory settings and No will cancel the operation. Yes is selected by default.







4. Short press the **Menu**  **Button** to select **Yes** to confirm the factory reset. Factory settings will be restored and the PRO will reboot automatically; **OR**
5. Short press the **Up**  or **Down**  **Button** to select **No** and short press the **Menu**  **Button** to confirm cancellation of the factory reset and return to the submenu.

### NOTES:

- There is a pause of about 10 seconds before the factory restart begins. Do not press any buttons during this time.
- A factory reset cannot be undone.
- The settings listed below will be reset to the factory defaults:
  - Color Palette: White Hot
  - Display Brightness: 3
  - Image Sharpness: 3
  - Magnification: 1.5x / 3x
  - Ultra-Clear mode: Off
  - Wi-Fi: Off
  - Video Output: Off
  - Calibration: Automatic
  - Digital Compass: Off
  - Motion Sensor: Off
  - Reticle Type: 1
  - Reticle Color: Black
  - Microphone: Off
  - Standby: Off
  - Language: English
  - Status Bar: Hide
  - Wi-Fi SSID: RH50Pro\_XXXXXX
  - Wi-Fi Password: 12345678

## SETTINGS MENU > INFO

### Show device information

1. In the settings submenu, short press the **Up**  or **Down**  **Button** to select the info  menu item.
2. Short press the **Menu**  **Button** to enter the info submenu.
3. The info submenu will display the following information about the PRO: the product model, GUI version, SYS Info, boot version, FPGA, PN, and SN number, and hardware version.
4. Long press the **Menu**  **Button** to return to the home screen.

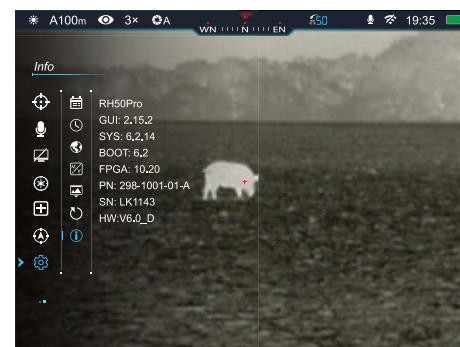

## 25. BASIC INSPECTION

It is recommended to carry out a technical inspection before each use. Please check the following:

- The rifle scope appearance: there should be no cracks in the body or visible damage.
- The condition of the objective lens and eyepiece: there should be no cracks, greasy spots, dirt, or other deposits on the lens.
- The internal rechargeable battery pack should be fully charged.
- The control buttons should be in working order.

## 26. BASIC MAINTENANCE

Always replace the objective lens cap (1) after use to avoid damaging or scratching the lens. Never touch the lens directly; oil from your skin can damage the lens coating and surface.

Basic maintenance should be carried out at least twice a year and includes the following steps:

- Wipe the surface of the external metal and plastic components with a clean, dry cotton cloth. Do not use chemical, corrosive, or abrasive cleaners. Canned air may also be used to clean the external components.
- Clean the electric contacts and battery slots on the rifle scope using a non-greasy organic solvent.
- Check the lens and eyepiece. If necessary, remove any dirt or sand from the optics; a non-contact cleaning method is preferred.
- Cleaning the exterior of the lens should only be done with the included microfiber lens cloth or a similar product. Only clean the lens when it is visibly soiled. Frequent wiping or cleaning can degrade the anti-reflective lens coating.

## 27. WARRANTY

At iRayUSA we're first and foremost hunters and users of our products and we understand that failure isn't an option. We also understand that having to wait extended periods for repair isn't something that a customer should have to put up with when something does go wrong. During your published warranty period, iRayUSA will repair or replace, at its discretion, any optic that becomes defective during normal use. Additionally, if we cannot fix your optic in less than one week, we will offer to replace it with a replacement product in like or better condition. If you would rather wait for your specific optic to be repaired, we can handle that too.

We know you've never seen this from a thermal manufacturer, neither have we, and that's why we started iRayUSA.

Our warranty follows the product and is not tied to the original owner. The warranty period is tied to the date of sale to the dealer. This warranty only covers normal use and does not cover cosmetic damage, normal wear, intentional damage, theft, loss, any act of God, or a condition caused by use other than intended. Any product that is modified, opened, or tampered with will void any warranty coverage. Any serial number damage or alteration on the product will be considered a modification. Be sure to register your RICO PRO rifle scope at [irayusa.com/register](http://irayusa.com/register).

To return a product for repair:

1. Go to [irayusa.com/warranty](http://irayusa.com/warranty) and click the **Request an RMA button** to request an RMA number. Returns will not be accepted without an RMA.
2. The customer is responsible for shipping the product to iRayUSA, per the instructions included in the RMA. iRayUSA will return the product at no cost.
  - The one-week timeline starts from the time of receipt of the product at iRayUSA.
  - iRayUSA is not liable for any damages or loss incurred when shipping to iRayUSA.
  - This warranty gives you specific legal rights, and you may also have other rights which vary from state to state.

Please give us a call at **800-769-7125**, visit [irayusa.com/warranty](http://irayusa.com/warranty), or email [info@irayusa.com](mailto:info@irayusa.com) with any questions.

## 28. GENERAL TROUBLESHOOTING

The troubleshooting table on the next page lists issues that may occur when operating the RICO PRO. Carry out the recommended troubleshooting steps in the order shown in the table. Please contact iRayUSA at 800-769-7125 or [irayusa.com/support](http://irayusa.com/support) or an authorized vendor for assistance before attempting to perform any modifications or repairs beyond the scope of the troubleshooting procedures in this manual. Unauthorized repairs or modifications will void your warranty.



ISSUE	POSSIBLE CAUSES
The PRO will not turn on.	The built-in battery pack is very low or has completely discharged.
The PRO can not connect to a computer or external power supply.	External power supply has completely discharged.
	Computer is turned off.
	Data cable is damaged.
Video output is not working.	Video output is not turned on
The PRO can not connect to the mobile device (smartphone or tablet).	Wi-Fi is not turned on.
	Wrong Wi-Fi password entered.
	Too many Wi-Fi signals nearby.
Wi-Fi signal is lost or interrupted.	Smartphone or tablet is out of range of a strong Wi-Fi signal, or there are obstacles between the PRO and the mobile device.
The image is fuzzy, not clear, not balanced, with artifacts.	Non-uniformity correction is required.
The image is too dark.	Display brightness level is too low.
The GUI is clear, but the image is fuzzy.	The lens is not focused.
	There is dust on the interior or exterior optical surfaces of the lens.
	There is condensation on the interior or exterior optical surfaces of the lens.
The aiming reticle shifts after firing rounds.	The PRO is not mounted securely or the mount is not secured on the PRO.
The image of the object being observed is missing.	Looking through glass.
The PRO will not focus.	Image settings are not optimal for the current environmental conditions or the object being observed.
Image quality is too low or the detection range is reduced.	These issues may occur due to the weather conditions, such as snow, rain, humidity, and fog.
When the PRO is used in low-temperature conditions, the image quality of the surroundings is worse than in warm-temperature conditions.	Environmental conditions.

TROUBLESHOOTING STEPS
Charge the built-in battery pack.
Charge the external power supply.
Power on the computer.
Replace the data cable.
Turn on video output in the main menu. See <b>Main Menu &gt; Video Output</b> on page 28.
Turn on Wi-Fi in the main menu. See <b>Main Menu &gt; Wi-Fi</b> on page 27
On the mobile device, go to <b>Settings &gt; Wi-Fi</b> and enter the correct password. The default password is 12345678. See <b>Main Menu &gt; Wi-Fi</b> on page 27.
Move the RICO PRO and mobile device to an area with no or fewer Wi-Fi signals.
<ul style="list-style-type: none"> <li>• Try again when Wi-Fi signal is stable.</li> <li>• Relocate the PRO closer to the Wi-Fi signal.</li> </ul>
Perform a non-uniformity correction. See <b>Non-uniformity Correction</b> on page 21 and <b>Main Menu &gt; Calibration</b> on page 28.
Adjust the display brightness in the quick menu. See <b>Using the Quick Menu</b> on page 18.
<ul style="list-style-type: none"> <li>• Adjust the focus on the target by rotating the Objective Focus Knob (2)</li> <li>• Adjust the image sharpness in the quick menu. See <b>Using the Quick Menu</b> on page 18.</li> </ul>
<ul style="list-style-type: none"> <li>• Wipe the outside optical surfaces with the included microfiber lens cloth.</li> </ul>
<ul style="list-style-type: none"> <li>• Wipe the outside optical surfaces with the included microfiber lens cloth.</li> <li>• Allow the PRO to dry by leaving it in a warm, dry environment for at least 4 hours.</li> </ul>
<ul style="list-style-type: none"> <li>• Check that the PRO has been securely mounted.</li> <li>• Make sure you are using the same brand, type, and weight of the bullets as when the PRO and weapon were initially zeroed.</li> <li>• If the PRO was zeroed in different environmental conditions, a slight shift of the zero is possible.</li> </ul>
Remove any glass windows from the field of view.
<ul style="list-style-type: none"> <li>• Check the outer surfaces of the objective lenses and eyepiece and wipe away any dust, condensation, frost, etc.</li> <li>• In cold weather, you can use special anti-fogging coatings, such as those made for corrective glasses.</li> <li>• Adjust the focus on the target by rotating the Objective Focus Knob (2).</li> <li>• Adjust the image sharpness in the quick menu. See <b>Using the Quick Menu</b> on page 18.</li> <li>• Adjust the image and device settings. See <b>Quick Start Guide</b> on page 8.</li> <li>• Turn on Ultra-Clear mode. See <b>Main Menu &gt; Ultra-Clear</b> on page 27.</li> </ul>
Turn on Ultra-Clear mode. See <b>Main Menu &gt; Ultra-Clear</b> on page 27.
In warm-temperature conditions, objects being observed (surroundings and background) heat up differently because of thermal conductivity, thereby generating a high temperature contrast. Accordingly, the image quality produced by the rifle scope will be higher. In low-temperature conditions, the background will cool down to roughly the same temperature, and thus the temperature contrast is substantially reduced and image detail can go down as there is less contrast in the scene. This is a normal function of a thermal imager and is no indicator of actual detector performance.

**30. NOTES**

Horizontal ruling lines for notes on page 48.

Horizontal ruling lines for notes on page 49.

***iRAYUSA***

**800-769-7125**

**682-499-0047**

**info@irayusa.com**

**PN: IRAY-PR150**