

INFIRAY OUTDOOR
RICO G FAMILY

Rugged Infrared Compact Optic



WARNING! ITAR REQUIREMENTS

These products may be subject to export and foreign trade control laws of the United States and may not be exported without prior approval of the U.S. Department of State. Learn more at irayusa.com/ITAR.

CAUTION

Use of controls or adjustments or performance of procedures other than those specified herein may result in hazardous radiation exposure.

iRayUSA 800 Railhead Road #316 Fort Worth TX 76106
800.769.7125 info@irayusa.com

NOTICE: This product is a Class 3R laser product.



Explanatory Label



Mfr ID and Certification Label

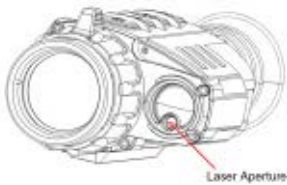

NOTE: There is no scheduled maintenance or service necessary to keep this product in compliance and no user service or maintenance is required.

This Laser Product is designated as Class 3R during all procedures of operation.

Wavelength: 905nm
Laser Power for Classification: 1.8µJ
Emission Type: Pulsed
Beam Diameter: <3mm at aperture
Divergence: <1mRad

**INVISIBLE LASER RADIATION
AVOID DIRECT EYE EXPOSURE
CLASS 3R LASER PRODUCT**

NOTES:

- There is no service required or allowed of this product by the end user.
- This product is to be serviced or repaired only by factory authorized technicians.
- This product is not to be opened or modified by the user.
- The user is not to modify the unit or remove protective covers or housing. Service is only to be handled by authorized factory trained technicians. This product has no user-serviceable parts.
- Do not point laser or allow laser light to be directed or reflected toward other people or reflective objects.
- Operators should be trained to not target the eyes of people, animals, and pets or aim at reflective objects, etc.
- There is a potential hazard of eye or skin exposure to laser radiation if the included instructions are not followed.
- This laser is never to be operated if the unit is defective or the cover or seal is damaged.
- Always operate the RICO G Family rifle scope with the aperture pointed downrange.

TABLE OF CONTENTS

| | |
|---|----|
| 1. How to Use This Manual | 2 |
| 2. RICO G-LRF Series Models | 2 |
| 3. RICO G-Series Models | 8 |
| 4. Battery Safety Warnings | 14 |
| 5. External Power Supply | 15 |
| 6. Description of Control Buttons & Shortcuts .. | 16 |
| 7. Quick Start Guide | 18 |
| 8. Mounting the Rifle Scope | 20 |
| 9. Operating Instructions | 21 |
| 10. Zeroing the Rifle Scope | 27 |
| 11. Non-Uniformity Correction | 28 |
| 12. Photography and Video Recording | 29 |
| 13. Accessing the Internal Memory | 30 |
| 14. Connecting to Wi-Fi | 31 |
| 15. Using the InfiRay Outdoor App | 33 |
| 16. Digital Zoom | 34 |
| 17. Picture in Picture (PIP) | 34 |
| 18. Laser Rangefinder | 35 |
| 19. Stadiametric & Fixed-Stadia Rangefinder | 36 |
| 20. Ultra-clear Mode | 38 |
| 21. Main Menu Options and Descriptions | 39 |
| 22. Basic Inspection | 59 |
| 23. Basic Maintenance | 59 |
| 24. Warranty | 60 |
| 25. FCC Statement | 61 |
| 26. General Troubleshooting | 61 |
| 27. Notes | 64 |

1. HOW TO USE THIS MANUAL

This manual contains information and operating instructions for RICO G-LRF Series and RICO G-Series rifle scopes.

For information specific to:

- **RICO G-LRF Series models, equipped with built-in laser rangefinder module**, please go to the next section below.
- **RICO G-Series models equipped with a stadiametric rangefinder only**, please go to page 8.

Information and instructions outside of these sections is applicable to all models unless otherwise noted.

2. RICO G-LRF SERIES MODELS

Overview

The RICO G-LRF Series introduces the next generation of thermal functionality, seamlessly combining InfiRay's industry-leading 12µm detector technology and a precision laser range-finding module in a single unit. The RICO G-LRF Series features a 1024×768 AMOLED display to guarantee a crisp, high-contrast image, while the precision laser rangefinding module ensures accurate measurement to 1000 yards. Additional features include image and video capture with 32GB of storage, wireless streaming, and a field-swappable 26650 battery with a 7-hour run-time.

Features

- 12µm high-performance thermal detector
- High image quality
- Reinforced polymer housing
- Maximum detection range 2400 yards
- Rechargeable 26650 battery
- HD 1024×768 AMOLED display
- High frame frequency: 50Hz
- Multiple zero profiles and ranges
- Digital Zoom: ×1/×2/×3/×4
- Built-in 32GB storage for image capture and video recording
- Built-in Wi-Fi module
- Mobile device App compatible
- Built-in digital compass and gravity sensor
- Multiple reticle types and color options
- Ultra-clear mode for advanced image detail
- Picture in Picture (PIP)
- Pixel calibration functions

Tech Specs

| RICO G-LRF SERIES | GL35R | GH50R |
|-------------------------------|---|----------------------|
| SENSOR | | |
| Resolution | 384×288 | 640×512 |
| Pixel Size | 12 µm | |
| Frame Rate | 50hz | |
| Image Processing | MATRIX III | |
| Core | InfiRay Micro II 384 | InfiRay Micro II 640 |
| OPTICS | | |
| Objective Lens | 35 mm f/1.0 | 50 mm f/1.1 |
| Magnification | 3× | |
| Digital Zoom | 4× | |
| Field of View | 7.5° × 5.7° | 8.8° × 6.6° |
| Detection Range | 1750 Yards | 2400 Yards |
| Display Type | AMOLED | |
| Display Resolution | 1024×768 | |
| Color Palettes | White Hot, Black Hot, Red Hot, Color, Highlight | |
| Reticle Types | 7 (2 Dynamic, 5 Static) | |
| Reticle Colors | Black, White, Red, Green | |
| Mounting System | Picatinny MIL-STD-1913 Rail | |
| P.I.P. | Yes | |
| Rangefinder | Internal Laser Rangefinder | |
| Eye Relief | 40 mm | 48 mm |
| Diopter Range | -4 to +4 | |
| ELECTRONICS | | |
| Onboard Recording | Video and Image | |
| Onboard Storage | 32 GB | |
| Wireless Connectivity | Video and Image via App. | |
| Data/Power Connector | USB-C | |
| Power Supply | USB-C External, 26650 Battery (7+ Hours) | |
| Start Up Time | <10 Seconds, Instant from Standby | |
| PHYSICAL | | |
| Size | 8.85" × 3.93" × 2.42" | |
| Weight | 23.9 Oz | 25.71 Oz |
| ENVIRONMENTAL/WARRANTY | | |
| Warranty | 5 Years | |
| Housing Material | Polymer | |
| Ingress Protection | IP67 | |
| Operation Temperature | -4°F~122°F | |
| Max. Recoil | 1000 g/s ² (300 Win./7mm Mag) | |

Accessories

The RICO G-LRF Series rifle scope ships with everything you need to get out and hunt.

| PART NO. | DESCRIPTION |
|--------------|--|
| IRAY-AC08 | USB-C to Analog RCA/USB Cable 36" |
| IRAY-AC17/12 | Objective Lens Cap for 35mm/50mm for RICO G Family |
| IRAY-AC13 | Standard QD Picatinny/Weaver Mount |
| IRAY-AC16 | Standard Rubber Eyeguard |
| --- | 26650 Battery 6800 mAh for RICO G-LRF Series |
| --- | 26650 Battery Charger |
| --- | USB Power Adapter |
| --- | M5 Screws for Picatinny Mount |
| --- | Spanner/T15 Tool |
| --- | Lens Cloth |
| --- | Soft Case |
| --- | Shoulder Strap for Soft Case |
| --- | User Manual |

Optional accessories for the RICO G-LRF Series are available to customize your experience, including replacement cables, batteries, and factory mounts, and the following accessories:

| PART NO. | DESCRIPTION |
|-----------|------------------------------------|
| IRAY-AC03 | RICO RQD Quick Release Mount |
| IRAY-AC08 | USB-C to Analog RCA/USB Cable 36" |
| IRAY-AC12 | Objective Lens Cap (50mm) |
| IRAY-AC13 | Standard QD Picatinny/Weaver Mount |
| IRAY-AC16 | Standard Rubber Eye Guard |
| IRAY-AC17 | Objective Lens Cap (35mm) |

Components and Controls

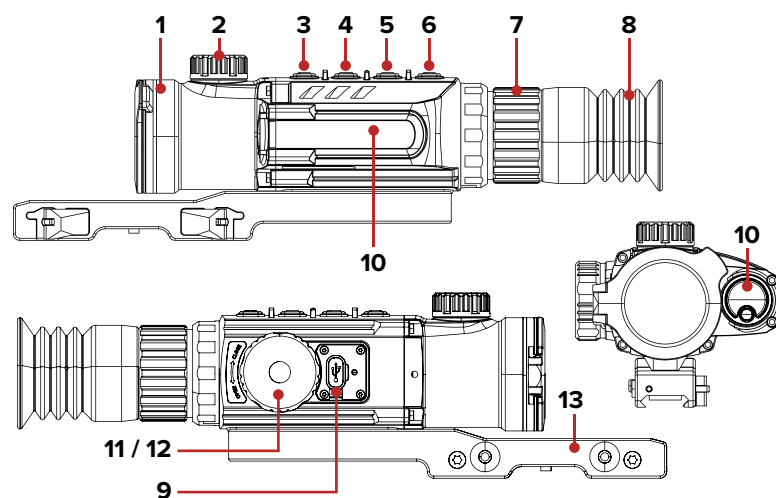

- 1 Objective Lens Cap
- 2 Objective Lens Focus Knob / Ring*
- 3 Power Button
- 4 Zoom / Up Button
- 5 Menu Button
- 6 Photo / Down Button
- 7 Eyepiece / Diopter Adjustment Ring
- 8 Eyeguard
- 9 USB-C Port
- 10 Laser Rangefinder Module
- 11 26650 Battery
- 12 Battery Cover
- 13 MIL-STD-1913 Picatinny Mount

*35mm models equipped with objective lens focus ring; 50mm models equipped with focus knob.

Charging, Installing, and Removing the Battery

The RICO G-LRF Series rifle scope comes with a 26650 long-lasting rechargeable lithium-ion 6800 mAh battery, which allows for 7 hours of operation. Fully charge the battery before using the RICO G-LRF for the first time.

CHARGING THE 26650 BATTERY WITH THE BATTERY CHARGER

1. Insert the 26650 battery (11) into the battery charger according to the polarity markings inside the charger.
2. Connect the charging cable to the battery charger.
3. Connect the charging cable to:
 - a. The included 5V–2A USB power adapter; **OR**
 - b. Any standard USB 3.0 port on a laptop/computer.
4. When fully charged, remove the battery from the charger. Do not overcharge.

WARNING: Never use the battery charger with a USB power adapter that is greater than 5V–2A.

WARNING: Only use the battery charger supplied with the battery. The use of any other charger may irreparably damage the battery, or the charger, and may cause a fire. Any damage from using an improper battery charger will not be covered by warranty.

POWERING THE G-LRF SERIES VIA THE USB-C PORT

The RICO G-LRF Series may be powered by an external power source when connected via the USB-C port (9).

1. Connect the small USB-C end of the data cable to the USB-C port (9) on the side of the G-LRF.
2. Connect the standard USB end of the data cable to:
 - a. The included 5V–2A USB power adapter; **OR**
 - b. Any standard USB 3.0 port on a laptop/computer; **OR**
 - c. An external power supply, such as a USB power bank.

NOTES:

- While powered via the data cable, the USB icon will be shown in the status bar onscreen.
- The 26550 battery does not charge when the rifle scope is connected to an external power source.

INSTALLING THE 26650 BATTERY

1. Remove the battery cover (12) by turning it counterclockwise.

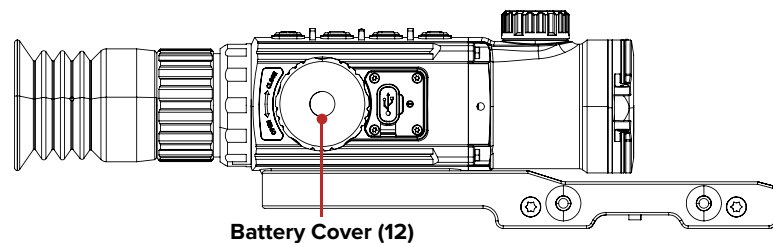

2. Insert a 26650 battery (11) into the battery compartment following the polarity markings inside the compartment. The positive [+] battery terminal faces in and the negative [-] terminal faces out.
3. Replace the battery cover.

WARNING: The G-LRF Series can only be powered by a 26650 battery. Using any other type battery may cause irreparable damage to the device or cause a fire. Any damage from using an improper battery will not be covered by warranty.

REMOVING THE BATTERY

To remove the battery from the G-LRF Series:

1. Remove the battery cover (12) by turning it counterclockwise.
2. Pull the battery out and replace the battery cover.

3. RICO G-SERIES MODELS (NON-LASER RANGEFINDING)

Overview

The RICO G-Series introduces the next generation of thermal functionality, seamlessly combining InfiRay's industry-leading 12µm detector technology and a 1024x768 AMOLED display guaranteed to deliver a crisp, high-contrast image. The RICO G-Series takes image processing to an incredible level with advanced image correction and automatic image optimization courtesy of its MATRIX III processor. Additional features include image and video capture with 32GB of storage, wireless streaming, and two field-swappable IBP-2 batteries, which combined with the built-in battery provide a 11+ hour run-time.

Features

- 12µm high-performance thermal detector
- High image quality
- Reinforced polymer housing
- Maximum detection range 2400 yards
- Rechargeable battery
- HD 1024×768 AMOLED display
- High frame frequency: 50Hz
- Multiple zero profiles and ranges
- Digital Zoom: ×1/×2/×3/×4
- Built-in 32GB storage to support image capture and video recording
- Built-in Wi-Fi module
- Mobile device App compatible
- Built-in digital compass and gravity sensor
- Multiple reticle types and color options
- Ultra-clear mode for advanced image detail
- Picture in Picture (PIP)
- User-friendly interface
- Pixel calibration functions

Tech Specs

| RICO G-SERIES | GL35 | GH35 | GH50 |
|-------------------------------|---|-----------------------|-----------------------|
| SENSOR | | | |
| Resolution | 384×288 | 640×512 | 640×512 |
| Pixel Size | 12 µm | | |
| Frame Rate | 50hz | | |
| Image Processing | MATRIX III | | |
| Core | InfiRay Micro II 384 | InfiRay Micro II 640 | InfiRay Micro II 640 |
| OPTICS | | | |
| Objective Lens | 35 mm f/1.0 | 35 mm f/1.0 | 50 mm f/1.1 |
| Magnification | 3× | 2× | 3× |
| Digital Zoom | 4× | | |
| Field of View | 7.5° × 5.7° | 12.6° × 9.4° | 8.8° × 6.6° |
| Detection Range | 1750 Yards | 1750 Yards | 2400 Yards |
| Display Type | AMOLED | | |
| Display Resolution | 1024×768 | | |
| Color Palettes | White Hot, Black Hot, Red Hot, Color, Highlight | | |
| Reticle Types | 7 (2 Dynamic, 5 Static) | | |
| Reticle Colors | Black, White, Red, Green | | |
| Mounting System | Picatinny MIL-STD-1913 Rail | | |
| P.I.P. | Yes | | |
| Rangefinder | Stadiametric | | |
| Eye Relief | 40 mm | 48 mm | 48 mm |
| Diopter Range | -4 to +4 | | |
| ELECTRONICS | | | |
| Onboard Recording | Video and Image | | |
| Onboard Storage | 32 GB | | |
| Wireless Connectivity | Video and Image via App. | | |
| Data/Power Connector | USB-C | | |
| Power Supply | USB-C External, Built-In Battery Pack (5 Hours), IBP-2 Li-ion Battery Pack ×2 (3+ Hours Each) | | |
| Start Up Time | <10 Seconds, Instant from Standby | | |
| PHYSICAL | | | |
| Size | 8.85" × 3.93" × 2.42" | 8.82" × 3.54" × 2.48" | 8.82" × 3.54" × 2.48" |
| Weight | 25.75 Oz | 26.10 Oz | 27.51 Oz |
| ENVIRONMENTAL/WARRANTY | | | |
| Warranty | 5 Years | | |
| Housing Material | Polymer | | |
| Ingress Protection | IP67 | | |
| Operation Temperature | -4°F~122°F | | |
| Max. Recoil | 1000 g/s ² (300 Win./7mm Mag) | | |

Accessories

The RICO G-Series rifle scope ships with everything you need to get out and hunt.

| PART NO. | DESCRIPTION |
|--------------|--|
| IRAY-AC08 | USB-C to Analog RCA/USB Cable 36" |
| IRAY-AC17/12 | Objective Lens Cap for 35mm/50mm for RICO G Family |
| IRAY-AC13 | Standard QD Picatinny/Weaver Mount |
| IRAY-AC16 | Standard Rubber Eyeguard |
| IRAY-AC38 | IBP-2 Li-ion Battery Pack 3.1Ah/3.6V |
| IRAY-AC39 | InfiRay Outdoor IBC-2 Battery Charger |
| --- | USB Power Adapter |
| --- | M5 Screws for Picatinny Mount |
| --- | Spanner/T15 Tool |
| --- | Lens Cloth |
| --- | Soft Case |
| | Shoulder Strap for Soft Case |
| --- | User Manual |

Optional accessories for the RICO G-Series are available to customize your experience, including replacement cables, batteries, and factory mounts, and the following accessories:

| PART NO. | DESCRIPTION |
|-----------|---------------------------------------|
| IRAY-AC03 | RICO RQD Quick Release Mount |
| IRAY-AC08 | USB-C to Analog RCA/USB Cable 36" |
| IRAY-AC12 | Objective Lens Cap (50mm) |
| IRAY-AC13 | Standard QD Picatinny/Weaver Mount |
| IRAY-AC16 | Standard Rubber Eye Guard |
| IRAY-AC17 | Objective Lens Cap (35mm) |
| IRAY-AC38 | IBP-2 Li-ion Battery Pack 3.1Ah/3.6V |
| IRAY-AC39 | InfiRay Outdoor IBC-2 Battery Charger |

Components and Controls

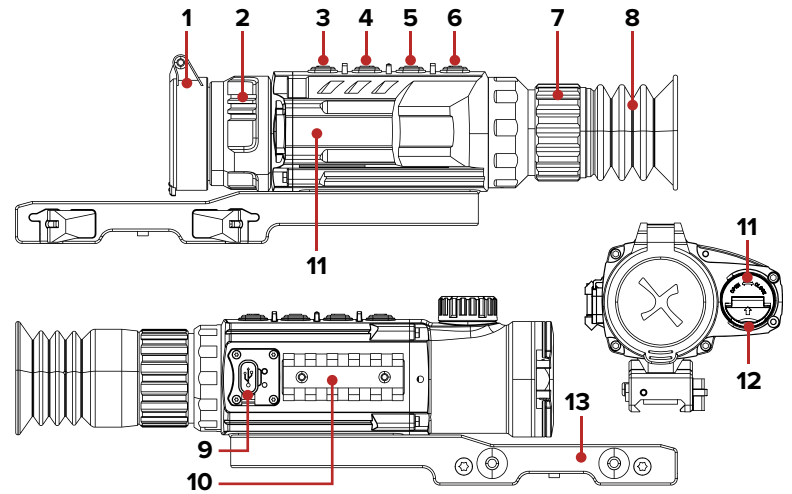

- 1 Objective Lens Cap
- 2 Objective Lens Focus Ring / Knob*
- 3 Power Button
- 4 Zoom / Up Button
- 5 Menu Button
- 6 Photo / Down Button
- 7 Eyepiece / Diopter Adjustment Ring
- 8 Eyeguard
- 9 USB-C Port
- 10 Accessory Rail
- 11 Auxiliary (IBP-2) Battery
- 12 Battery Pull-Tab
- 13 MIL-STD-1913 Picatinny Mount

*35mm models equipped with objective lens focus ring; 50mm models equipped with focus knob.

Charging, Installing, and Removing the Battery

The RICO G-Series rifle scope comes with a built-in, long-lasting rechargeable lithium-ion 4400mAh battery pack, which allows for 5+ hours of operation. The G-Series also comes with two IBP-2 long-lasting rechargeable lithium-ion 3300mAh batteries, which allow for 3+ hours of operation each.

Fully charge both the internal and auxiliary batteries before using the RICO G-Series for the first time.

CHARGING VIA THE USB-C PORT

1. Connect the small USB-C end of the data cable (15) to the USB-C port (9) on the side of the G-Series.
2. Connect the standard USB end of the data cable to:
 - a. The included 5V–2A USB power adapter (16); OR
 - b. Any standard USB 3.0 port on a laptop/computer; OR
 - c. An external power supply, such as a USB power bank.

NOTES:



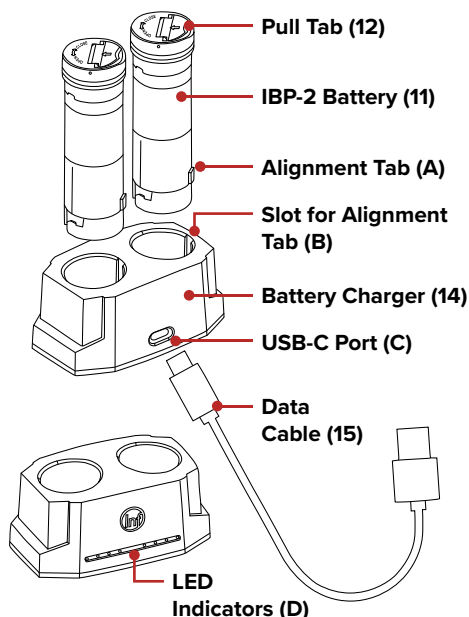

- You may charge and operate the G-Series at the same time.
- While charging, the battery status icon shown in the status bar onscreen will change to the charging  icon.
- The internal battery will be charged first. Once the internal battery reaches full-charge, charging will switch automatically to the auxiliary battery.

CHARGING WITH THE BATTERY CHARGER

1. Insert the IBP-2 battery (11) into the battery charger (14).
 - a. Align the small rectangular tab (A) near the bottom of the battery with the long shallow slot (B) in the side of the charger.
2. Connect the small USB-C end of the data cable (15) to the USB-C port (C) on the battery charger.



3. Connect the standard USB end of the data cable to:
 - a. The included 5V–2A USB power adapter (16); OR
 - b. Any standard USB 3.0 port on a laptop/computer.
4. During charging, the LED indicators (D) on the battery charger will indicate the current charge level:

| LED INDICATOR | BATTERY CHARGING STATUS |
|--|-------------------------|
|  | 1% – 25% charged |
|  | 25% – 50% charged |
|  | 50% – 75% charged |
|  | 75% – 99% charged |
|  | Fully charged |

NOTE: The half-circle icons indicate flashing LEDs.

5. When fully charged, remove the battery from the charger.
 - a. It takes about 4 hours to fully charge the battery. Do not overcharge.

WARNING: Never use the battery charger with a USB power adapter that is greater than 5V–2A.

WARNING: Only use the battery charger (14) supplied with the battery. The use of any other charger may irreparably damage the battery, or the charger, and may cause a fire. Any damage from using an improper battery charger will not be covered by warranty.

INSTALLING THE AUXILIARY BATTERY

1. Slide the IBP-2 battery (11) into the battery compartment.
 - a. Align the small rectangular alignment tab (A) near the bottom of the battery with the long shallow slot (B) on the inside of the battery compartment (at about 5 o'clock).
2. Grab the pull-tab (12) and press the battery in firmly while twisting it clockwise to the horizontal position to lock the battery in place.

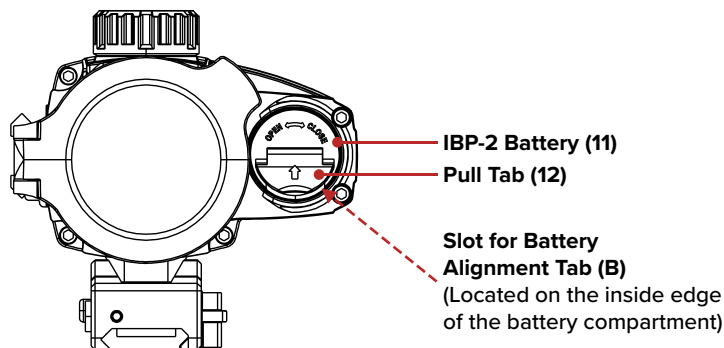

3. Flip the pull-tab down so that it is flush with the battery.

WARNING: The G-Series rifle scope can only be powered by a factory-supplied IBP-2 battery. Using any other battery may cause irreparable damage to the device or cause a fire. Any damage from using an improper battery will not be covered by warranty.

Removing the Auxiliary Battery

To remove the battery from the G-Series:

1. Lift the pull-tab (12) on the battery (11).
2. Press the IBP-2 battery in firmly while rotating the battery counterclockwise about 20-degrees until it pops out.
3. Pull the battery out.

4. BATTERY SAFETY WARNINGS

WARNING: Only use your RICO G Family rifle scope with the supplied battery-type (26650 for G-LRF Series models, IBP-2 for G-Series models). The use of any other battery type may irreparably damage the battery or the charger, and may cause a fire. Any damage from using an improper battery charger will not be covered by warranty.

WARNINGS:



- Do not use a battery charger, power adapter, or USB cable that has been modified or damaged.
- Do not expose the battery to high temperatures or flames, and do not immerse in water.
- Do not leave the battery unattended while charging.
- Do not leave the battery in the charger for long periods after full charge is reached. Charging time should not exceed 24 hours.
- Keep the batteries out of the reach of children and pets.
- The battery is equipped with short-circuit protection. However, any situation that may cause short-circuiting should be avoided.
- Do not disassemble, modify, hit, or drop the battery.
- Do not connect the battery to any external device with an electrical current that exceeds permitted levels.
- Do not connect an external device with a current supply that exceeds 3.0 USB port.

To maintain optimal battery capacity and service life:

- Avoid storing a fully charged or discharged battery for long periods. Partial charging the battery is necessary if the battery will be stored for an extended period.
- Do not charge an extremely cold battery without bringing it into a warm environment. Let the battery warm up for 45 minutes before charging.
- Charge the battery at a temperature range from 32°F to 113°F, otherwise the service life of the battery may be reduced.
- The recommended operation temperature range is -4°F to 122°F. Avoid using the battery above the maximum or below the minimum recommended temperature range as this may decrease the battery capacity or service life.

5. EXTERNAL POWER SUPPLY

The rifle scope supports the use of an external power supply, such as a 5V mobile power bank.



1. Connect the external power supply to the USB-C port (9).
2. The rifle scope will switch to operation from the external power supply, and the battery will begin slowly charging.
 - a. **G-LRF models:** The main battery status icon in the status bar will change to a USB  icon.
 - b. **G-Series models:** The main battery status icon in the status bar will change to a charging battery  icon, with the battery color indicating the current charge level (green, yellow, red).
 - c. See **Battery Status** on page 24 for additional information.
3. If the external power supply is disconnected, the rifle scope will automatically switch to the battery, when installed, without powering off.

NOTE: Do not connect the rifle scope to an external device with a power supply that exceeds the 3.0 USB cable.

6. DESCRIPTION OF CONTROL BUTTONS AND SHORTCUTS

| Power Button  | | |
|--|---|----------------------|
| Current Screen, Menu, or Device Status | Short Press | Long Press |
| Device off | --- | Power on the device |
| Home screen | Enter manual standby mode | Power off the device |
| Standby mode | Wake device from standby mode | --- |
| Main menu | Exit menu without saving changes | --- |
| Defective pixel correction interface | Add or remove defective pixel from the "to be corrected list" | --- |
| Reticle zeroing interface & laser rangefinder calibration interface (G-LRF models only) | Exit interface without saving | --- |



| Zoom / Up Button  | | |
|--|---|--|
| Current Screen / Menu | Short Press | Long Press |
| Home screen | Adjust digital zoom | Enter laser rangefinder (G-LRF Series models only) |
| | | Enter / exit fixed-stadia rangefinder (G-Series models only) |
| Main menu / quick menu | Move cursor up | --- |
| Defect pixel correction & reticle zeroing interfaces | Move cursor 1 pixel in the positive direction | Move cursor 10 pixels in the positive direction |
| Stadiametric rangefinder (G-Series models only) | Expand horizontal lines by 1 pixel | Expand horizontal lines by 10 pixels |

| Zoom + Photo Button  +  | | |
|---|--|--|
| Current Screen / Menu | Short Press | Long Press |
| Home screen | Perform a manual non-uniformity correction (NUC) | Perform a background non-uniformity correction (NUC) |
| Reticle zeroing interface | --- | Freeze image to keep reticle centered on aiming point; press again to clear frozen image |

| Menu Button  | | |
|---|---|---|
| Current Screen / Menu | Short Press | Long Press |
| Home screen | Enter quick menu | Enter main menu |
| Main menu | Change menu options; enter submenu; or confirm submenu changes and return | Save and return to home screen |
| Quick menu | Toggle through menu options | Exit quick menu |
| Defective pixel correction interface | Toggle between axis of movement (X or Y) | Correct pixel(s) and return to previous OR cancel pixel correction and return to previous |
| Reticle zeroing interface | Toggle between axis of movement (X or Y) | Save new reticle position |
| Laser rangefinder calibration interface (G-LRF models only) | Toggle between axis of movement (X or Y) | --- |

| Zoom + Menu Button  +  | | |
|--|--------------------------|--|
| Current Screen / Menu | Short Press | Long Press |
| Home screen | Turn PIP window on / off | Enter / exit the stadiametric rangefinder (G-Series models only) |

| Photo / Down Button  | | |
|---|---|---|
| Current Screen / Menu | Short Press | Long Press |
| Home screen | Take photo | Start / stop recording video |
| Quick menu / main menu | Move cursor down | --- |
| Defect pixel correction & reticle zeroing interfaces | Move cursor 1 pixel in the negative direction | Move cursor 10 pixels in the negative direction |
| Stadiametric rangefinder (G-Series models only) | Contract horizontal lines by 1 pixel | Contract horizontal lines by 10 pixels |

| Zoom + Menu + Photo Button  +  +  | | |
|--|---------------------------------------|---|
| Current Screen / Menu | Short Press | Long Press |
| Home screen | --- | Activate / deactivate reticle (Long press for 10 seconds) |
| Laser rangefinder (G-LRF Series models only) | Toggle units between yards and meters | --- |

7. QUICK START GUIDE

Step 1: Preparing to Use the Rifle Scope

1. Compare the box contents to the accessories list and examine each for any shipping damage. See page 4 for the G-LRF Series accessories and page 10 for the G-Series accessories.
2. Check the lens to ensure there are no smudges or dirt present. Clean with the included lens cloth, if necessary.
3. Install the eyeguard (8).
4. Charge the battery (11) before using the rifle scope for the first time. See page 6 for G-LRF Series instructions and page 12 for G-Series instructions.
5. Insert the battery into the battery compartment. See page 6 for G-LRF Series instructions and page 13 for G-Series model instructions.
6. Mount the rifle scope to the weapon. See **Mounting the Rifle Scope** on page 20.

Step 2: Power On and Adjust the Focus

1. Open the objective lens cap (1).
2. Long press the **Power**  button for 3 seconds to power on the rifle scope. The iRayUSA logo will appear.
3. Rotate the diopter adjustment ring (7) of the eyepiece until the interface icons are clearly visible.

WARNING: Do not point the objective lens toward intense energy sources, such as the sun. This may render the electronic components inoperative. The warranty does not cover damage caused by improper operation.

Step 3: Adjust Image Settings in the Quick Menu

Short press the **Menu**  Button to enter the quick menu to adjust the following settings (see **Using the Quick Menu** on page 25):

1. Select the imaging mode, white hot, black hot, red hot, color, or highlight. The default is white hot.
2. Select the display brightness, from 1–5. The default is 3.
3. Select the image sharpness, from 1–5. The default is 3.

Step 4: Adjust Device Settings in the Main Menu



Long press the **Menu**  Button to enter the main menu to adjust the following settings:

1. Select the desired non-uniformity correction (NUC) mode: automatic, manual, or background. The default is automatic.



See **Main Menu > Calibration** on page 41 and **Non-Uniformity Correction** on page 28.

2. Turn on the microphone. See **Main Menu > Microphone** on page 40.
3. Turn on the digital compass. See **Main Menu > Compass** on page 41.
4. Turn on the gravity sensor. See **Main Menu > Gravity Sensor** on page 42.
5. Calibrate the digital compass, as needed. See **Main Menu > Compass Calibration** on page 54.
6. In the settings submenu:
 - a. Set the date and time. See **Settings Menu > Date** and **Settings Menu > Time** on page 55.
 - b. Select the units of measure, meters or yards. The default is meters. See **Settings Menu > Units of Measure** on page 56.

Step 5: Adjust Digital Zoom and PIP Settings

1. From the home screen, short press the **Zoom**  Button to toggle through the four zoom options, 1×, 2×, 3×, and 4×. The real-time amplification number appears in the status bar. See **Digital Zoom** on page 34.
2. From the home screen, short press the **Zoom**  and **Menu**  Buttons to turn on the PIP window. A 2× zoomed image (2× that of the total zoom shown in the status bar) will appear in the top of the screen. See **Picture in Picture (PIP)** on page 34.

Step 6: Set Up the Reticle & Zero the Rifle Scope

1. From the home screen, press and hold the **Zoom** , **Menu** , and **Photo**  Buttons at the same time for 10 seconds to activate the reticle for the first time.
2. Select the zeroing profile, A, B, or C. See **Reticle Menu > Zeroing Profile** on page 43.
3. Select the reticle type, 1–7. See **Reticle Menu > Reticle Type** on page 43.
4. Select the reticle color, white, black, red, or green. See **Reticle Menu > Reticle Color** on page 44.
5. Zero the rifle scope. See **Zeroing the Rifle Scope** on page 27.
 - a. Select, or customize, a preset zero distance that matches the target distance. See **Zeroing Menu > Zero Distance Submenu** on page 45.
 - b. Zero the reticle. See **Zeroing Menu > Reticle Zeroing** on page 45.

8. MOUNTING THE RIFLE SCOPE

Installing the Picatinny Mount

Before using the rifle scope, you need to install the MIL-STD-1913 Picatinny mount rail (13) to the bottom.

The three mounting holes in the base of the rifle scope enable the mount (13) to be installed in multiple configurations. This allows the shooter to set the correct eye-relief distance for the rifle type.

1. Install the Picatinny mount (13) to the base of the rifle scope using a 3mm hex key and the M5 screws (18) supplied in the package.

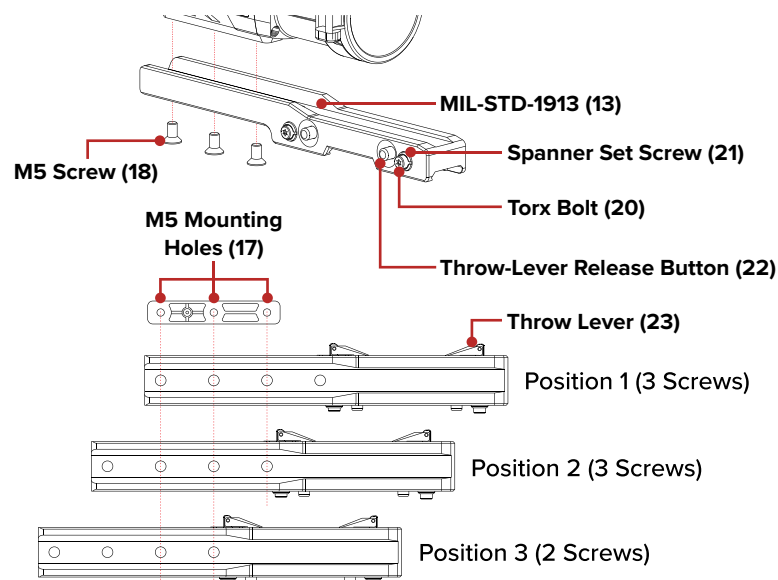

2. Install the rifle scope to the rifle and adjust its position so that it produces a clear image and is comfortable to the shooter.
3. When the location is suitable, remove the rifle scope from the rifle, remove the M5 screws, and apply a small amount of blue Locktite 242 to the threads of the screws.
4. Reinsert the screws and tighten them to 20 in/lbs.

NOTE: Please note, torque is inch pounds, NOT foot pounds. If you do not have a torque wrench, apply until snug. Do not overtighten.

The rifle scope is now ready to be zeroed. See **Zeroing the Rifle Scope** on page 27 for instructions.

Adjusting Arm Tension

NOTE: Use a calibrated torque wrench, or the included T15 torx tool (19), to ensure the proper amount of torque is applied to the mounting hardware. Damage caused by overtightening the hardware is not covered under warranty.

1. Twist the T15 torx bolt (20) CLOCKWISE to loosen. This will allow the spanner set screw (21) to the outside of the bolt to move freely.

NOTE: Torx bolts are reverse-thread screws. Clockwise loosens and counterclockwise tightens.

- a. Use the included spanner/torx tool (19) to adjust the spanner set screw, which will adjust the contact point of the throw lever (23).
 - b. Clockwise tightens and counterclockwise loosens.
 - c. When the lever reaches about halfway closed (45-degrees), it should start to require more force to close. Proper adjustment should be snug but still allow the mount to be applied and removed easily by hand. Do not overtighten.
2. With the mount attached and the throw lever closed after proper adjustment, twist the torx bolt counterclockwise to 20 in/lbs to lock the spanner set screw in place. Do not overtighten.

IMPORTANT NOTE: If installing an aftermarket mount, do not apply more than 20 in/lbs to the M5 mounting screws.

9. OPERATING INSTRUCTIONS

WARNING!

Don't point the objective lens towards any intense energy sources, such as laser radiation or the sun. This may render the electronic components inoperative. The warranty does not cover damage caused by improper operation.

Shortcut Buttons

The rifle scope is operated via four control buttons. The control buttons can be used to perform shortcut operations from the home screen, as well as in the menu and full-screen interfaces. See **Description of Control Buttons and Shortcuts** on page 16 for shortcut button details.



Power On / Starting

1. Open the objective lens cap (1).
2. Long press the **Power**  button for 3 seconds to turn on the rifle scope. The iRayUSA logo will appear.

To determine the current battery charge, check the battery icon on the right side of the status bar at the top of the viewscreen. See **Battery Status** on page 24.

Powering Off / Stopping

To power off the rifle scope:

1. Long press the **Power**  button. The standby screen will open, showing a 3-second countdown.
2. Continue holding the **Power**  button until the 3-second countdown completes.
3. “Data saving...” appears onscreen and the rifle scope will shut down automatically after saving.

NOTE: Releasing the **Power**  Button at any time during this shutdown cycle will stop the shutdown process and the rifle scope will resume its normal operation.

WARNING: If using an external power supply, do not remove the power supply when saving data, otherwise the data may not be saved.

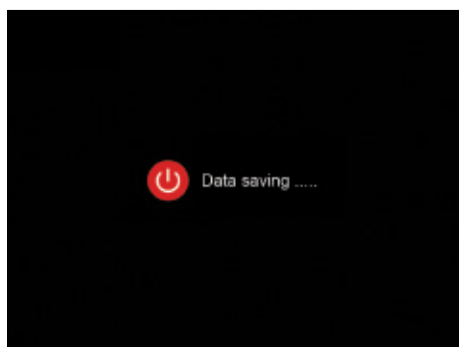
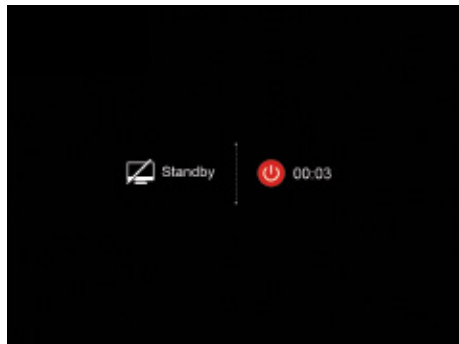



STANDBY MODE

Standby mode may be activated either manually or automatically to conserve battery life.

Automatic Standby Mode

In the main menu, the rifle scope may be set to automatically enter standby mode after a specified time with no operation (2, 4, or 6 minutes).

1. In the main menu, select the desired standby time, 2, 4, or 6 minutes. See **Main Menu > Standby** on page 48 for instructions.
2. The standby icon  and status (2min, 4min, 6min, or off) appear on the right side of the status bar.
3. Once set, the rifle scope will automatically enter standby mode after the set number of minutes of inactivity to conserve battery life.
4. When in automatic standby mode, short press the **Power**  Button to exit standby and return to the home screen.

NOTES:

- When **2min**, **4min**, or **6min** is selected:
 - The rifle scope will enter standby mode automatically when the it is tilted up or down at an angle of more than 70° or left or right at an angle of more than 30°.
 - The rifle scope will not enter standby mode while it is in a level firing position.
- When **off** is selected, standby mode is turned off and the rifle scope will operate until the batteries run out.

Manual Standby Mode

Manual standby mode may be activated at any time.

1. From the home screen, short press the **Power**  Button to activate / deactivate manual standby.

Adjusting the Focus

ADJUSTING THE DIOPTR/ EYEPIECE

1. Rotate the eyepiece diopter adjustment ring **(7)** at the rear of the rifle scope right or left until the user interface onscreen is clear.
2. Look closely to ensure all screen symbols, the status bar, and the reticle appear sharp and in focus. No additional diopter adjustments are required unless the user wishes to make changes.

NOTES:

- After the initial adjustment, there is no need to rotate the eyepiece adjustment ring **(7)** for long distances or other conditions.
- If necessary during standard use, you may rotate the objective lens focus ring/knob **(2)** to adjust fine focus on the target object being observed. See **Focusing the Objective Lens**.

FOCUSING THE OBJECTIVE LENS



To adjust the focus on the target object:

1. Rotate the objective lens focus knob/ring **(2)** left or right to adjust fine focus on the target object being observed.

NOTE: Re-adjusting the focus will be necessary if the distance to your target changes.

Activate / Deactivate the Reticle

The reticle is inactive when the rifle scope is powered on for the first time. To activate the reticle, or to deactivate it at a later time:

1. From the home screen, press and hold the **Zoom** , **Menu** , and **Photo**  Buttons at the same time for 10 seconds.

Status Bar Overview

The status bar at the top of the screen shows information on the operating status of the RICO rifle scope:



1 2 3 4 5 6 7 8 9 10 11 12

- 1 **Imaging Mode:** Shows the set imaging mode, white hot ☀️; black hot ☾; red hot 🔥; color 🇺🇦; highlight 🐦. White hot is the default.
- 2 **Zeroing Profile & Distance:** Shows the selected zero profile, A, B, or C, and zero distance.
- 3 **Ultra-clear Mode:** Shows the Ultra-clear status, on 👁️ or off 🚫. Ultra-clear mode is off by default.
- 4 **Total Magnification:** Shows the total magnification.
- 5 **Non-Uniformity Correction (NUC) Mode:** Shows the non-uniformity correction (NUC) mode 🔄 icon and selected mode, automatic (A), manual (M), and background (B). A countdown timer icon will appear instead of the calibration mode when 5 seconds remain until an automatic NUC.
- 6 **Digital Compass:** Displays when the compass is turned on. Compass is off by default.
- 7 **Standby:** Shows standby time 🕒 (2, 4, 6 min) or 🚫 off. Standby is off by default.
- 8 **Microphone:** Shows the microphone status, on 🗣️ or off 🚫. Microphone is off by default.
- 9 **Wi-Fi:** Shows the Wi-Fi status, on 📶 or off 🚫. Wi-Fi is off by default.
- 10 **Time:** Shows the current time in 24-hour format.
- 11 **Main Battery:** Shows the status of the main battery: the 26650 battery for G-LRF Series models or the built-in battery pack for G-Series models).
- 12 **Auxiliary (IBP-2) Battery (G-Series Models):** Shows the status of the auxiliary battery: when the icon is in color, the IBP-2 is the active battery; when the icon is gray, the IBP-2 is the non-active battery; when the icon is gray and empty, the battery needs to be charged; when a slashed gray battery icon appears, no IBP-2 is installed.
- 13 **USB Icon:** When the USB cable is connected, the USB icon appears in place of the main battery icon (G-LRF Series models) or below the status bar (G-Series models).

BATTERY STATUS

Battery icon color indicates the current battery status. The battery icon is replaced by the charging battery icon or USB icon when an external power supply is connected.

| COLOR / ICON | BATTERY STATUS |
|------------------|--|
| Green Battery | 41% – 100% |
| Yellow Battery | 20% – 40% |
| Red Battery | <20%; charge the battery right away. |
| Gray Battery | Inactive battery |
| Empty Battery | Auxiliary (IBP-2) battery is empty and needs to be charged (G-Series models only). |
| Slashed Battery | Auxiliary (IBP-2) battery is not installed (G-Series models only). |
| Charging Battery | Battery is charging. |
| USB | External power supply or computer is connected via the data cable. |

Using the Quick Menu

In the quick menu, the imaging mode, display brightness, image sharpness, and zero distance may quickly be adjusted.



1. On the home screen, short press the **Menu [M] Button** to enter the quick menu.
2. Press the **Up / Zoom [Q] Button** or **Down / Photo [C] Button** to move between the menu options below. The selected menu item is highlighted in the background.
 - a. **Image Mode:** Short press the **Menu [M] Button** to change the image mode, white hot, black hot, red hot, color, and highlight.
 - b. **Display Brightness:** Short press the **Menu [M] Button** to change the display brightness level, from 1–5.
 - c. **Image Sharpness:** Short press the **Menu [M] Button** to change the image sharpness level, from 1–5.
 - d. **Zero Distance:** Short press the **Menu [M] Button** to select a new zero distance within the currently selected zeroing profile. Only the zero distances in the selected profile will be available for selection. The selected zeroing distance appears on the left side of the status bar.

3. Long press the **Menu** **[M]** **Button** to save any changes and return to the home screen.

NOTE: In the quick menu, if there is no user input for 5 seconds, the rifle scope will automatically save any changes and return to the home screen.

Navigating the Main Menu

From the home screen, long press the **Menu** **[M]** **Button** to enter the main menu.

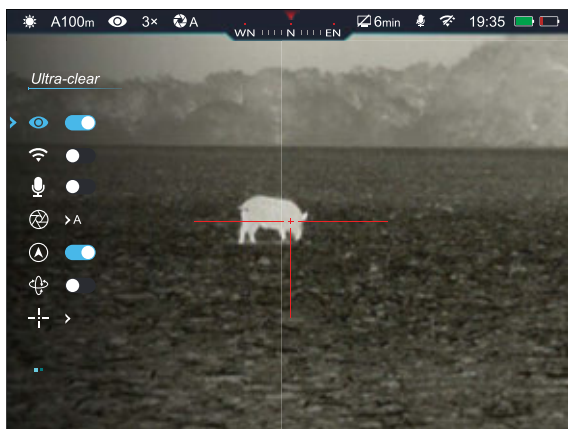

In all menu interfaces:

- Short press the **Up / Zoom** **[Q]** **Button** or **Down / Photo** **[C]** **Button** to move up and down through the menu to switch between the main menu options.
- A blue cursor indicates the current position in the menu.
- Short press the **Menu** **[M]** **Button** to:
 - Change the current parameters for the selected menu option; **OR**
 - Enter the submenu; **OR**
 - Confirm submenu changes and return to previous menu.
- Long press the **Menu** **[M]** **Button** to confirm any changes and exit to the home screen.
- Short press the **Power** **[P]** **Button** to return to the previous menu without saving.
- After 15 seconds of inactivity, the menu will automatically close and the interface will return to the home screen. Changes (except changes to toggle on / off menu items, such as Ultra-clear and Wi-Fi) are not saved automatically.
- Upon exiting from the main menu the cursor location is stored for a single working session (until the rifle scope is turned off). After restarting the rifle scope and entering the menu, the cursor position will be at the first menu item.

10. ZEROING THE RIFLE SCOPE

The RICO G Family of rifle scopes feature a “freeze” zeroing method. To zero the rifle scope:

1. Set a suitable target at the desired zero distance.
2. Confirm that the rifle is empty, safe, and pointed in a safe direction, with no ammunition near the weapon.
3. Adjust the image and device settings following the steps in the **Quick Start Guide** on page 18, if you have not done so already.
4. Select the zeroing profile, A, B, or C. See **Reticle Menu > Zeroing Profile** on page 43.
5. Based on the distance to the target you wish to zero, select a preset zero distance, **OR** customize one of the preset zero distances to match. The rifle scope supports custom zeroing distances of 1 to 999 meters or 1 to 999 yards. See **Zeroing Menu > Zero Distance Submenu** on page 45.
6. Ensure a stable platform and natural shooting position is achieved behind the rifle.
7. Load ammunition, aim, and take one good shot at the target.
8. Make your rifle safe and observe the location of impact on the target.
9. If the point of impact does not match the point of aim (the center of the reticle), adjust the X/Y position of the reticle.
10. In the submenu for the selected zero distance, center the reticle on the aiming point and long press the **Zoom** **[Q]** and **Photo** **[C]** **Buttons** at the same time to freeze the image.
11. Select the axis (X or Y) along which to move the reticle by short pressing the **Menu** **[M]** **Button** to toggle between X and Y.
12. Adjust the X/Y position of the reticle until the reticle matches the point of impact.
 - a. Use the **Up** **[Q]** **Button** to move in the positive direction: X= Right and Y= Up.
 - b. Use the **Down** **[C]** **Button** to move in the negative direction: X= Left and Y= Down.
 - c. Upon moving the reticle, a white dot appears onscreen, representing the original position of the reticle.
13. Long press the **Menu** **[M]** **Button** to save the reticle position.
14. Take a confirmation shot—the point of impact should now match the point of aim. If not, adjust the X/Y position of the reticle again.

For detailed Zeroing instructions, please see **Zeroing Menu > Reticle Zeroing** on page 45.

11. NON-UNIFORMITY CORRECTION

A non-uniformity correction (NUC) allows a thermal imager's sensors to correct its pixels and eliminate any image defects caused by pixel drift. A NUC will be performed automatically each time the rifle scope is powered on.

The rifle scope has three NUC modes, automatic (**A**), manual (**M**), and background (**B**). The selected NUC mode (**A**, **M**, or **B**) appears on the left side of the status bar. For instructions on setting the NUC mode in the main menu, see **Main Menu > Calibration** on page 41.

Automatic Mode

In automatic mode (**A**), the rifle scope will perform a NUC automatically according to the internal software algorithm. There is no need to close the objective lens cap (**1**) as the rifle scope's internal shutter covers the sensor.



A countdown timer will appear in the status bar instead of the calibration mode when 5 seconds remain until an automatic NUC is performed. Pressing the **Power**  **Button** during the 5-second countdown will interrupt a pending NUC for approximately 45 seconds. The timer will appear only after the microbolometer temperature has stabilized—after approximately 10 minutes of continuous operation of the rifle scope.

NOTE: A manual NUC (see below) may be performed at any time while in Automatic (**A**) mode.

Manual Mode

In manual mode (**M**), the user independently determines the need to perform a NUC based on the quality of the observed image. It is not necessary to close the objective lens cap (**1**) during a manual NUC, as the internal shutter covers the sensor.

To perform a manual NUC while in manual mode (or automatic mode):



1. From the home screen, short press the **Zoom**  and **Photo**  **Buttons** at the same time.
2. A manual NUC is performed instantly.

Background Mode

In background mode (**B**), the user independently determines the need to perform a background NUC based on the quality of the observed image. A background NUC uses less power than an automatic or manual NUC because it does not use the imager shutter to cover the sensor; instead, the user must close the lens cap (**1**).

To perform a background NUC while in background mode:

1. Close the objective lens cap (**1**).

2. From the home screen, long press the **Zoom**  and **Photo**  **Buttons** at the same time.
3. A prompt to close the lens cap (**1**) appears onscreen. The background NUC starts after about 4 seconds.

NOTE: If the lens is not properly covered, a temporary “image burn” will remain in the image until the next non-uniformity correction. This “image burn” is temporary and is not a defect or sign of permanent damage.

12. PHOTOGRAPHY AND VIDEO RECORDING



The RICO G Family rifle scopes are equipped with video recording and image capture.

Photo and video files are named with the time and date; therefore, it is recommended to set the date and time before using the photo and video functions. See **Settings Menu > Date** and **Settings Menu > Time** on page 55. Alternately, the date and time may be synchronized with one button in the InfiRay Outdoor App. See **Using the InfiRay Outdoor App** on page 33.

NOTE: All videos and photos are automatically saved to the rifle scope's built-in 32 GB memory storage.





Photography

To take a photo:

1. From the home screen, short press the **Photo**  **Button**.
2. The image will freeze for 0.5 seconds and the camera  icon will appear in the upper-left corner of screen.

Video Recording

To record video:

1. Turn on the microphone in the main menu, if desired. See **Main Menu > Microphone** on page 40.
2. From the home screen, long press the **Photo**  **Button** to start a video recording.
3. When the video recording starts, the video  icon and the video recording timer, in HH:MM:SS (hour: minute: second) format, appear in the upper-left corner of the screen.
4. When recording, short press the **Photo**  **Button** to take a photo.
5. Long press the **Photo**  **Button** to stop and save the video recording.

Video and Photography Tips

- You may enter and navigate the menu as normal during video recording. The user interface (the status bar, icons, and menu) is not captured in recorded video or photo files.
- Recorded photos are saved to the internal memory card of the in .jpg format, videos are saved in .mp4 format.
 - a. Photos are saved in IMG_HHMMSS_XXX.jpg format.
 - b. Videos are saved in VID_HHMMSS.mp4 format.
 - c. HHMMSS is hour/minute/second.
 - d. XXX is a 3-digit counter number.
- The counter used for multimedia file names cannot be reset.
- If a file is deleted from the internal memory, its counter number is not taken by another file.

CAUTION:

- The maximum duration of a recorded video file is 5 minutes. After this time, video recording will begin a new file automatically.
- The number of the recorded files is limited only by the capacity of the internal memory.
- Check the available space on the internal storage card regularly and move video footage and images to other storage media to free up space on the memory card.
- Graphic data (icons and menu) are not displayed in recorded video and photo files.

13. ACCESSING THE INTERNAL MEMORY

When the rifle scope is turned on and connected to a computer via the included data cable, it is recognized by the computer as a flash memory (USB) drive. This allows the user to access the saved multimedia files and copy or delete any desired files.

To access the internal memory:

1. Turn on the rifle scope.
2. Plug the smaller USB-C end of the data cable (15) into the USB-C port (9).
3. Plug the larger USB end of the data cable into your computer.
4. Double-click **My Computer** on your computer desktop.
5. Double-click to open the device named **Infiray**.
6. Double-click to open the device named **Internal Storage** to access the built-in memory.

- a. The device shows the available space (in GB) remaining of the 32GB of total memory storage.
- b. Recorded photos and videos are separated by date into folders.
- c. Folders are named by date, in YYYYMMDD (year/month/day) format.

7. Select the desired files or folders to copy or delete.

14. CONNECTING TO WI-FI

The RICO G Family of rifle scopes have a function for wireless communication with a mobile device (smartphone or tablet) via Wi-Fi. When Wi-Fi is successfully connected, the user may manipulate the rifle scope via the InfiRay Outdoor App. See **Using the InfiRay Outdoor App** on page 33.

To enable the wireless module:

1. In the main menu, turn on Wi-Fi. See **Main Menu > Wi-Fi** on page 40 for instructions.
2. When Wi-Fi is on, the Wi-Fi  icon displays in the status bar.

In the InfiRay Outdoor App:

1. Scan one of the QR codes in **Using the InfiRay Outdoor App** on page 33 to download the InfiRay Outdoor App from the App Store or Google Play.
2. Open the app and press the **ViewFinder**  icon at the bottom of the screen.
3. The ViewFinder screen will prompt the user to: Open the mobile device > Go to device settings > Turn on device Wi-Fi > Connect to Wi-Fi.
4. Click the **Connect Device WiFi** button.

On the mobile device:

1. Go to **Settings > Wi-Fi**.
2. Select the rifle scope from the list of Wi-Fi networks.
 - a. G-LRF Series models: Appear in the list as **GENI_XXXXXX**.
 - b. G-Series models: Appear in the list as **Geni_XXXXX_XXXXXX**.
 - c. X's indicate the model's serial number. See **Settings Menu > Info** on page 58 for the serial number (SN).
3. Enter the Wi-Fi password. The default password is 12345678.
4. Press the **Join** button.



Firmware Upgrade

When a firmware update is available, it may be sent to the rifle scope through Wi-Fi connection.

To check for and download an available firmware update:

1. On your mobile device, go to irayusa.com/fwpc.
2. If an update is available for the rifle scope, it will be listed at the top of the screen (look for your model number: GL35R, GH50R, GL35, GH35, or GH50).
3. Click the available update to download it.
4. Confirm you wish to download the file and select where to save the .img file on your mobile device.

To upgrade the rifle scope:

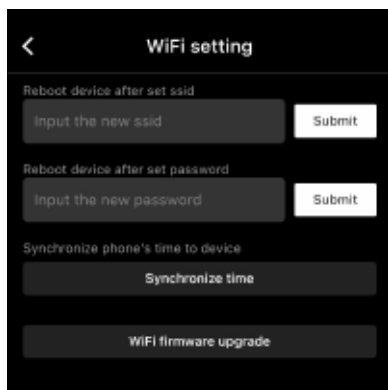

1. On the rifle scope, turn on Wi-Fi to connect to the App. See **Main Menu > Wi-Fi** on page 40.
2. Open the InfiRay Outdoor App.
3. In the App, press the **ViewFinder**  icon at the bottom of the screen.
4. Press the **Settings**  icon at top-right.
5. Press the **WiFi Firmware Upgrade** button.
6. Press the **Choose Firmware** button to browse for the saved .img file on your mobile device.
7. Press the **Start Upgrading** button. The app will display the current upload progress. The rifle scope will automatically reboot when the upgrade has completed.



Setting a New Wi-Fi Password and SSID

The Wi-Fi SSID and password for the rifle scope can be reset in the InfiRay Outdoor App. The default password is 12345678.

After connecting with a mobile device:

1. Open the InfiRay Outdoor App.
2. Press the **ViewFinder**  icon at the bottom of the screen.
3. Press the **Settings**  icon.

4. In the password field, enter the new Wi-Fi password, and press the **Submit** button. The password must be 8–16 numbers/letters.
5. If you also wish to reset the SSID, enter a new Wi-Fi name in the SSID field, and press the **Submit** button.
6. Turn off the rifle scope to put the new password (and SSID, if changed) into effect.
7. Wait at least 30 seconds before restarting the device.
8. On the mobile device, go to **Settings > Wi-Fi**, enter the new password, and press the **Join** button.

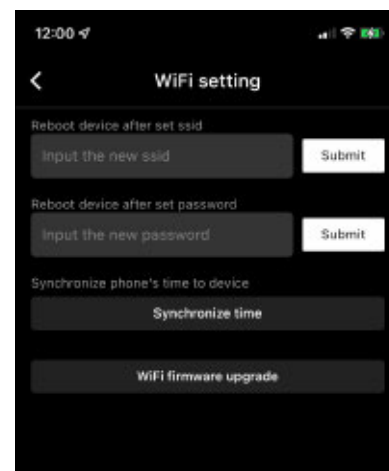

NOTE: When a factory reset is performed, the Wi-Fi SSID and password are reset to the defaults, Geni_XXXXX_XXXXXX OR GENI_XXXXXX, and 12345678. See **Settings Menu > Factory Reset** on page 57.

15. USING THE INFIRAY OUTDOOR APP



The RICO G Family of rifle scopes support operation via the InfiRay Outdoor App when the rifle scope is connected via Wi-Fi to a smartphone or tablet. See **Main Menu > Wi-Fi** on page 40.

You can download and install the InfiRay Outdoor App for free via any app store, or by scanning one of the QR codes at right to download the InfiRay Outdoor App from the App Store or Google Play.



When Wi-Fi is connected, users can manipulate the rifle scope via the InfiRay Outdoor App, including:

- Take real-time photos and videos, with or without audio.
- Photos and videos taken via the App are saved to the mobile device, instead of the rifle scope's internal storage. Once connected, you can access files saved to the mobile device:
 - In the App, press the **ViewFinder** icon  at the bottom of the screen.

- Press the photo and video icons at the bottom of the screen to view photos and videos, as well as share, delete, and download files.
- Change the Wi-Fi password and SSID. See **Setting a New Wi-Fi Password and SSID** on the previous page.
- Synchronize date and time from the mobile device with the rifle scope:
 - In the App, press the **ViewFinder icon**  at the bottom of the screen.
 - Press the **Settings icon**  at top-right.
 - Click the **Synchronize Time button**.
- Upgrade the firmware. See **Firmware Upgrade** on page 32.

16. DIGITAL ZOOM

The RICO G Family of rifle scopes will quickly increase the basic magnification by enlarging the image from 1 to 4 times digitally.

To adjust the digital zoom:

1. From the home screen, short press the **Zoom**  **Button** to toggle through the digital zoom levels, 1×, 2×, 3×, to 4×. The total magnification is displayed in the status bar.
2. The following table lists the real-time amplification corresponding to each digital zoom level.



| Model | BASE MAGNIFICATION | DIGITAL ZOOM MAGNIFICATIONS | | | |
|--------------------------------|--------------------|-----------------------------|----|----|----|
| | | 1× | 2× | 3× | 4× |
| GL35 GH50 GL35R GH50R | 3× | 3 | 6 | 9 | 12 |
| GH35 | 2× | 2 | 4 | 6 | 8 |

17. PICTURE IN PICTURE (PIP)

The Picture in Picture (PIP) function opens a small floating window with a magnified image-view at the top of the screen. PIP allows for improved aiming while still being able to see the wide field of view in the main body of the screen.

When the PIP window is activated, a 2× zoomed image, centered on the reticle, will appear at the top of the screen. Please note that the PIP image is 2× that of the total magnification shown on the left side of the status bar. When the image in the main body of the screen is enlarged via digital zoom, the PIP image will enlarge accordingly.

To enter / exit Picture in Picture mode:

1. From the home screen, short press the **Zoom**  and **Menu**  **Buttons** at the same time.

18. LASER RANGEFINDER (G-LRF SERIES ONLY)

The G-LRF Series models are equipped with an integrated, precision laser rangefinder which allows the user to measure the distance to objects up to 1000m away, with $\pm 1m$ accuracy up to 1km. The laser rangefinder has continuous rangefinding which allows the user to adjust quickly to changing distances for better shot placement.



CAUTION: Do not stare directly into the laser.

To use the laser rangefinder:





1. Long press the **Zoom**  **Button** to enter the laser rangefinder.

NOTE: The laser will turn on automatically when you enter the laser rangefinder interface.

2. The laser rangefinder interface has the following features:
 - 1 **Cursor:** The square blue rangefinder cursor appears in the center of the screen.
 - 2 **CONT:** Continuous rangefinding (the measurement is updated continuously, in real-time).
 - 3 **Ranging Value:** The distance to the selected target and unit of measurement, **m** (meters) or **y** (yards) appears in the upper-left corner.

3. Locate the target. The distance to the target will be continuously updated by the rangefinder.

NOTE: When the target is more than 1000m (1093yd) away, “MAX” will appear instead of the ranging value.

4. Short press the **Zoom** , **Menu** , and **Photo**  **Buttons** at the same time to toggle between meters and yards.
5. Long press the **Zoom**  **Button** to exit the laser rangefinder.

ACCURACY NOTES:



- Accuracy of measurement and maximum range depend on the reflection ratio on the target surface, the angle at which the emitting beam falls on the target surface and environmental conditions. Reflectivity depends on the surface texture, color, size, and shape of the object. Typically, a glossy, bright surface presents higher reflectivity than a darker surface.
- Accuracy of measurement can also be affected by illumination conditions, fog, smog, rain, snow etc. Ranging performance can degrade in bright condition or when ranging towards the sun.
- Measuring the range to a small target is more difficult than measuring to a large target.
- Accuracy of measurement can also be affected by low battery or dirty or smudged objective lens.

19. STADIAMETRIC & FIXED-STADIA RANGEFINDER (G-SERIES ONLY)

Stadiametric Rangefinder





G-Series models have a stadiametric rangefinder which allows the user to calculate the approximate distance to an object, if its size is known.

To use the stadiametric rangefinder:

1. From the home screen, long press the **Zoom**  and **Menu**  Buttons at the same time to open the stadiametric rangefinder interface.
2. The stadiametric rangefinder interface has the following features:
 - 1 **Stadia Lines:** The two horizontal lines in the center of the screen can be adjusted in order to measure the size of the target object.
 - 2 **Icons and Distances:** Icons for five pre-configured prey types and their distance values will be displayed on the left side of the screen. The pre-configured objects and distance values in the stadiametric rangefinder are:



| PREY TYPE | HEIGHT (FEET) | DISTANCE | |
|-----------|---------------|----------|--------|
| | | YARDS | METERS |
| Deer | 5.7 | 1.9 | 1.7 |
| Hog | 3.0 | 1.0 | 0.9 |
| Coyote | 1.5 | 0.5 | 0.5 |
| Rabbit | 0.6 | 0.2 | 0.2 |
| Custom | 3.3 | 1.1 | 1.0 |

3. Use the stadiametric rangefinder to calculate the size of the observed object:
 - a. Expand or contract the space between the horizontal lines until they touch the top and bottom edges of the target object.
 - b. Press the **Up/Zoom**  Button to expand the space between the lines.
 - c. Press the **Down/Photo**  Button to shrink the space between the lines.
4. As you adjust the space between the horizontal lines, the rangefinder values on the left side of the screen are automatically recalculated.
5. Long press the **Zoom**  and **Menu**  Buttons at the same time to exit the stadiametric rangefinder.

NOTES:

- The stadia lines are centered on the reticle, which remains onscreen.
- To change the units of measurement (meters or yards), see **Settings Menu > Units of Measure** on page 46.

Fixed-Stadia Rangefinder

G-Series models also have a fixed-stadia rangefinder which allows the user to quickly determine when a target is within range based on previously entered prey height and distance values.

To use the fixed-stadia ranging interface:

1. In the main menu, select the **Range Reference**  menu item. See **Main Menu > Range Reference** on page 49 for instructions.



- a. Select the desired prey type from the five pre-configured options.
 - b. Customize the prey height and distance, as needed.
 - c. Press and hold the **Menu** **[M]** **Button** to save and exit.
2. Press and hold the **Zoom** **[Q]** **button** to enter the fixed-stadia rangefinder.
 3. The fixed-stadia interface has the following features:
 - 1 **Two Fixed-Stadia Lines:** The horizontal lines indicate the size mapped to the selected prey type in the range reference interface. The horizontal lines are fixed and cannot be adjusted.
 - 2 **@Distance:** The user-input distance to the target in the range reference interface.
 - 3 **Prey Icon:** The selected prey type.
 - 4 **Height:** The user-input prey height in the range reference interface.
 4. Use the horizontal lines to determine if the observed object falls within the user-input distance:
 - a. When the object size matches the stadia lines, the target is at the user-input distance.
 - b. When the object is smaller or shorter than the stadia lines, the target is further than the user-input distance.
 - c. When the object is larger than the stadia lines, it is closer than the user-input distance.
 5. Press and hold the **Zoom** **[Q]** **button** to exit the fixed-stadia rangefinder.

NOTE: You may operate the menu normally while this interface is open.

20. ULTRA-CLEAR MODE

Ultra-clear mode improves the image quality in inclement weather conditions, such as rain, fog, high humidity, or high temperatures as these conditions all result in lower thermal contrast. Ultra-clear mode enhances the NETD value of the thermal sensor and improves the sensor's response rate to these challenging environment conditions.

Ultra-clear mode provides:

- Improved image quality and clarity; images are crisper and sharper.
- Increased image detail.
- Improved recognition of observed targets.

See **Main Menu > Ultra-Clear** on the next page.

21. MAIN MENU OPTIONS AND DESCRIPTIONS

Menu, and submenu, options, from top to bottom are:

- **Main Menu:** Ultra-clear, Wi-Fi, Microphone, Calibration, Compass, Gravity Sensor, Reticle, Zeroing, Standby, Range Reference, Rangefinder, Pixel Defect Correction, Compass Calibration, and Settings.
- **Reticle Menu:** Zeroing Profile, Reticle Type, and Reticle Color.
- **Zeroing Menu:** The three preset Zeroing Distance options (100m, 200m, 300m or 109y, 219y, 328y).
 - **Zeroing Distance Submenu:** Reticle Zeroing and Custom Zero Distance.
- **Settings Menu:** Date, Time, Languages, Units of Measure, Status Bar, Factory Reset, and Info.



Menu option details, descriptions and navigation instructions are listed in order on the following pages.

Ultra-clear

Turn Ultra-clear mode on / off

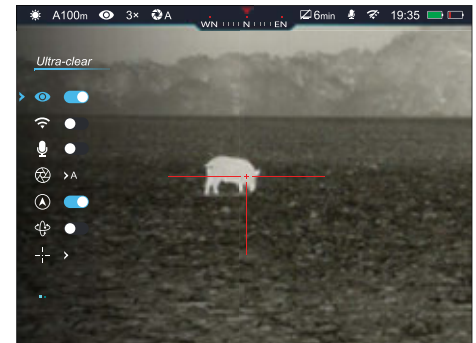
When Ultra-clear mode is turned on, the image contrast is enhanced, which is suitable for rainy, foggy, or low-contrast conditions. See **Ultra-clear Mode** on the previous page.











1. Long press the **Menu** **[M]** **Button** to enter the main menu.
2. Short press the **Up** **[Q]** or **Down** **[E]** **Button** to move through the menu to select the Ultra-clear  menu item.
3. Short press the **Menu** **[M]** **Button** to turn Ultra-clear on / off. Ultra-clear is off by default.
4. The Ultra-clear status, on  or off , appears on the left side of the status bar.
5. Long press the **Menu** **[M]** **Button** to return to the home screen.

NOTE: When Ultra-clear mode is turned on and off, the rifle scope will automatically perform a shuttered non-uniformity correction.

Wi-Fi

Turn Wi-Fi on / off









Turn on Wi-Fi to manipulate the rifle scope via the InfiRay Outdoor App. See **Connecting to Wi-Fi** on page 31.

1. Long press the **Menu  Button** to enter the main menu.
2. Short press the **Up  or Down  Button** to move through the menu to select the Wi-Fi  menu item.
3. Short press the **Menu  Button** to turn Wi-Fi on / off. Wi-Fi is off by default.
4. The Wi-Fi status, on  or off , appears on the right side of the status bar.
5. Long press the **Menu  Button** to return to the home screen.



Microphone

Turn the microphone on / off



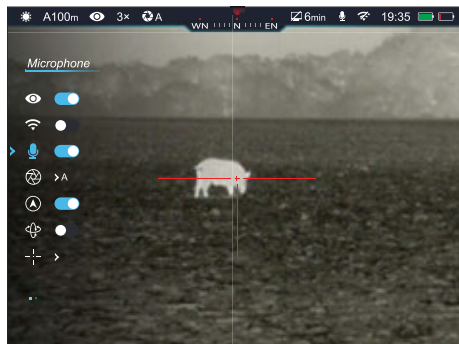





1. Long press the **Menu  Button** to enter the main menu.
2. Short press the **Up  or Down  Button** to move through the menu to select the microphone  menu item.
3. Short press the **Menu  Button** to turn the microphone on / off. The microphone is off by default.
4. The microphone status, on  or off , appears on the right side of the status bar.
5. Long press the **Menu  Button** to return to the home screen.



Calibration

Select calibration (non-uniformity correction) mode







The rifle scope has three non-uniformity correction (NUC) modes: Automatic (A), Manual (M) and Background (B). See **Non-uniformity Correction** on page 28 for details about each mode.

1. Long press the **Menu  Button** to enter the main menu.
2. Short press the **Up  or Down  Button** to move through the menu to select the calibration  menu item.
3. Short press the **Menu  Button** to enter the calibration submenu.
4. Short press the **Up  or Down  Button** to move through the calibration submenu options, Automatic (A), Manual (M) and Background (B). Automatic (A) is selected by default.
5. The selected NUC mode, A, M, or B, appears on the left side of the status bar.
6. Long press the **Menu  Button** to confirm the selection and return to the home screen.



Compass





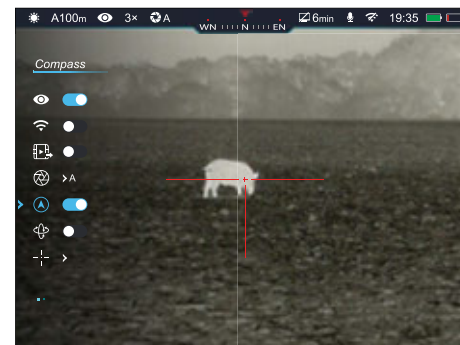

Turn the digital compass on / off

1. Long press the **Menu  Button** to enter the main menu.
2. Short press the **Up  or Down  Button** to move through the menu to select the compass  menu item.
3. Short press the **Menu  Button** to turn the digital compass on / off. The digital compass is off by default.
4. When the compass is on, it appears in the center of the status bar at the top of the screen.
5. Long press the **Menu  Button** to return to the home screen.



Gravity Sensor

Turn the gravity sensor on / off



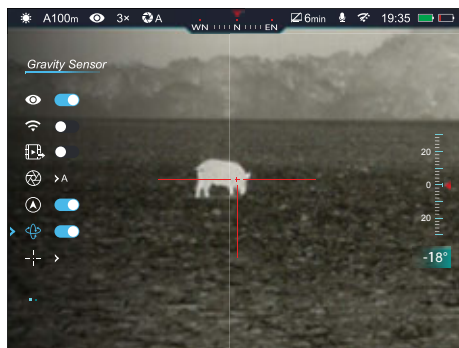

1. Long press the **Menu**  **Button** to enter the main menu.
2. Short press the **Up**  or **Down**  **Button** to move through the menu to select the gravity sensor  menu item.
3. Short press the **Menu**  **Button** to turn the gravity sensor on / off. The gravity sensor is off by default.
4. When the gravity sensor is on, the tilt angle appears on the left side of the screen and the pitch angle appears on the right side of the screen.
5. Long press the **Menu**  **Button** to return to the home screen.

NOTE: Tilt angle is not shown in the figure above because it is hidden by the menu.



Reticle





Select the zeroing profile, reticle type, and reticle color

1. Long press the **Menu**  **Button** to enter the main menu.
2. Short press the **Up**  or **Down**  **Button** to move through the menu to select the reticle  menu item.
3. Short press the **Menu**  **Button** to enter the reticle submenu.
4. There are three submenu items: zeroing profile, reticle type, and reticle color.



RETICLE MENU > ZEROING PROFILE







Select the zeroing profile

1. In the reticle submenu, the zeroing profile  menu item is selected by default.
2. Short press the **Menu**  **Button** to enter the zeroing profile submenu.
3. Short press the **Up**  or **Down**  **Button** to move through zeroing profile options, A, B, C. The default is A.
4. The selected zeroing profile, A, B, or C, appears on the left side of the status bar.
5. Long press the **Menu**  **Button** to confirm the selection and return to the home screen.



RETICLE MENU > RETICLE TYPE

Select reticle type

1. In the reticle submenu, short press the **Up**  or **Down**  **Button** to select the reticle type  menu item.
2. Short press the **Menu**  **Button** to enter the reticle type submenu.
3. Short press the **Up**  or **Down**  **Button** to move through reticle type options, 1-7 (see Reticle Types below). The default is reticle type 1. The reticle changes as the cursor moves through the reticle types.
4. Long press the **Menu**  **Button** to confirm the selection and return to the home screen.





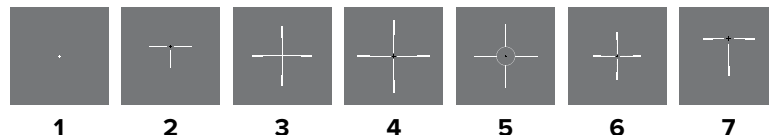



Reticle Types



RETICLE MENU > RETICLE COLOR

Select reticle color

1. In the reticle submenu, short press the **Up**  or **Down**  **Button** to select the reticle color  menu item.
2. Short press the **Menu**  **Button** to enter the reticle color submenu.
3. Short press the **Up**  or **Down**  **Button** to move through reticle color options, black, white, red, or green. The default is black. The reticle color changes as the cursor moves through the color options.
4. Long press the **Menu**  **Button** to confirm the selection and return to the home screen.







Zeroing

Select or customize zero distance

In the zeroing menu, you can select a preset zero distance, customize a preset zero distance, and adjust the reticle position for the selected zero distance. The rifle scope supports custom zero distances of 1 to 999 yards or 1 to 999 meters.





Before selecting or customizing a zero distance, you must select a zeroing profile, A, B, or C. Each zero profile has three zero distances. See **Reticle Menu > Zeroing Profile** on page 43.

1. Long press the **Menu**  **Button** to enter the main menu.
2. Short press the **Up**  or **Down**  **Button** to move through the menu to select the zeroing  menu item.
3. Short press the **Menu**  **Button** to enter the zeroing submenu. There are three zero distances shown in the submenu.



ZEROING MENU > ZERO DISTANCE SUBMENU 100m

Select, or customize, a preset zero distance



1. In the zero distance submenu, short press the **Up**  or **Down**  **Button** to select a zero distance option.
2. Short press the **Menu**  **Button** to enter the submenu for the selected zero distance.
3. In the submenu for the selected zero distance, you may:
 - a. Enter the reticle zeroing interface  to adjust the X/Y position of the reticle at the selected zero distance. See **Reticle Zeroing** on the next page.
 - b. Customize the selected preset zero distance, if desired. See **Zeroing Menu > Customize Zero Distance** on page 47.



ZEROING MENU > ZERO DISTANCE SUBMENU > RETICLE ZEROING

Adjust the reticle position of the selected zero distance.

In the reticle zeroing interface, the X/Y position of the reticle may be adjusted to match the point of impact. See **Zeroing the Rifle Scope** on page 27 for more details.

1. In the submenu for the selected zero distance, the reticle zeroing  menu item is selected by default. Short press the **Menu**  **Button** to select and enter the reticle zeroing interface.



2. The reticle zeroing interface has the following features:

- 1 **X:** Horizontal point of impact change (in cm or inches).
- 2 **Y:** Vertical point of impact change (in cm or inches).
- 3 **Freeze Icon:** Indicates that the image is frozen.
- 4 **Reticle:** Shows the new reticle position.
- 5 **White Dot:** Indicates the center of the initial reticle position.



NOTE: The red “X” indicates the point of impact. It is shown in the figure for illustration purposes and is not an interface element.

3. Center the reticle on the aiming point and long press the **Zoom** and **Photo** Buttons at the same time to freeze the image. The image freeze icon will appear below the X/Y coordinates.
4. Select the axis (X or Y) along which to move the reticle:
 - a. Short press the **Menu** Button to toggle between X and Y. The selected axis is indicated by a blue arrow and blue font. X is selected by default.
5. Adjust the X/Y position of the reticle until the reticle matches the point of impact.

a. X (horizontal) is the windage and Y (vertical) is the elevation.

b. Upon moving the reticle, a white dot appears onscreen, representing the original position of the reticle.



- c. Use the **Up** Button to move in the positive direction: X= Right and Y= Up.
- d. Use the **Down** Button to move in the negative direction: X= Left and Y= Down.
- e. Short press the **Up** or **Down** Button to move the reticle in the corresponding direction by 1 pixel; long press to move 10 pixels.

- f. When adjusting your zero at a distance of 50 yards, short press will change the impact point by 0.23” and long press moves 2.31” as shown in the X and Y coordinate displays. At 100 yards that same short press moves 0.46” and long press moves 4.63”. At 200 yards a short press moves 0.93” and a long press moves 9.26”.
 - g. Changing your zero distance will change the distance of your X/Y adjustments automatically. If your selected zero distance has a correction of 1.39” at 100 yards, it will automatically change to 2.78” if you change the zero distance to 200 yards.
6. Save **OR** clear the reticle position along the selected axis.
 - a. Short press the **Power** Button to clear the reticle position for the selected axis, returning the reticle to the original position for that axis; **OR**
 - b. Short press the **Menu** Button to save the position for the selected axis and switch to the other axis.
 7. Long press the **Menu** Button to save the reticle position for both axes and return to the home screen.
 - a. A 5-second countdown appears on the screen, followed by “Saved Successfully.”
 8. Take a confirmation shot—the point of impact should now match the point of aim. If not, adjust the X/Y position of the reticle again.

ZEROING MENU > ZERO DISTANCE SUBMENU > CUSTOMIZE ZERO DISTANCE

Customize a preset zero distance

The rifle scope supports custom zero distances of 1 to 999 yards or 1 to 999 meters.

1. In the submenu for the selected zero distance, short press the **Up** or **Down** Button to select the zero distance you wish to customize.
2. Short press the **Menu** Button to customize the selected preset zero distance. Blue triangle icons will appear above and below the selected digit to mark the cursor location. The far-left digit is selected by default.
3. Short press the **Up** or **Down** Button to increase or decrease the value of the selected digit, from 0–9.





- Short press the **Menu** **[M]** **Button** to switch between the three digits. The two triangle icons will indicate the selected digit.
- Long press the **Menu** **[M]** **Button** to save the custom zero distance and return to the zero distance submenu.
- The new zeroing distance appears on the left side of the status bar.

Standby

Set automatic standby status and time

To conserve battery, the rifle scope may be set to automatically enter standby mode after a specified number of minutes of inactivity (2, 4, or 6 minutes).



- Long press the **Menu** **[M]** **Button** to enter the main menu.
- Short press the **Up** **[Q]** or **Down** **[E]** **Button** to move through the menu to select the standby  menu item.
- Short press the **Menu** **[M]** **Button** to enter the standby submenu.
- Short press the **Up** **[Q]** or **Down** **[E]** **Button** to move through the standby submenu options, 2min, 4min, 6min, or off. Standby is off by default.
- The standby  icon and status (2min, 4min, 6min, or off) appear on the right side of the status bar.
- Long press the **Menu** **[M]** **Button** to confirm the selection and return to the home screen.
- When 2, 4, or 6 minutes is selected, the rifle scope will automatically enter standby mode after the set number of minutes of inactivity to conserve battery life.
- When in automatic standby mode, short press the **Power** **[P]** **Button** to exit standby and return to the home screen.



NOTES:

- When **2min**, **4min**, or **6min** is selected:
 - The rifle scope will enter standby mode automatically when it is tilted up or down at an angle of more than 70° or left or right at an angle of more than 30°.
 - The rifle scope will not enter standby mode while it is in a level firing position.
- When **off** is selected, standby mode is turned off and the rifle scope will operate until the batteries run out.
- Standby mode may be manually activated from the home screen at any time:
 - Short press the **Power** **[P]** to activate / deactivate manual standby mode.

Range Reference

Customize the five prey types

The rifle scope has five prey types (deer, hog, coyote, rabbit, and custom). Each prey type is has a default height at a range of 100m (109y). The distance range and height may both be adjusted for each prey type, as needed.

- Long press the **Menu** **[M]** **Button** to enter the main menu.
- Short press the **Up** **[Q]** or **Down** **[E]** **Button** to move through the menu to select the range reference  menu item.
- Short press the **Menu** **[M]** **Button** to enter the range reference submenu.
- The range reference interface has the following range elements:
 - Distance:** Set the distance range.
 - Target:** Select the icon for the target type you wish to customize.
 - Height:** Set the target height.

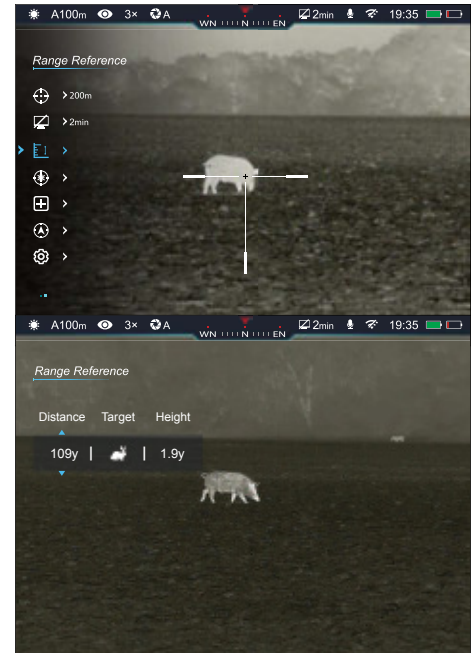

5. Short press the **Menu** **[M]** **Button** to move the cursor between the three range elements. The value of the selected element turns blue and blue triangle icons appear above and below it. Distance is selected by default.
6. Customize the value of the selected element:
 - a. Short press the **Up** **[Q]** or **Down** **[K]** **Button** to adjust:
 - i. **Prey height:** In increments of 0.1yd (0.1m), from .01yd to 3.3yd (0.1m to 3.0m).
 - ii. **Effective range:** In increments of 6yd (5m), from 27yd to 1092yd (25m to 999m).
 - b. Long press the **Up** **[Q]** or **Down** **[K]** **Button** to rapidly adjust height and distance values.
7. Long press the **Menu** **[M]** **Button** to save the any changes and return to the home screen.

Laser Rangefinder Calibration

Calibrate the laser rangefinder (G-LRF Series models only)

When the laser beam does not point to the center of the cursor in the laser rangefinder interface, the laser must be calibrated.



Over time, shooting can jar the position of the laser beam slightly off center. Typically, the laser calibration completed by the manufacturer can withstand over 1,000 impacts.

To calibrate the laser rangefinder:

1. Long press the **Menu** **[M]** **Button** to enter the main menu.
2. Short press the **Up** **[Q]** or **Down** **[K]** **Button** to move through the menu to select the rangefinder  menu item.
3. Short press the **Menu** **[M]** **Button** to enter the rangefinder calibration interface. The laser indicator light will turn on automatically.

CAUTION: Do not stare directly into the laser.

4. The rangefinder calibration interface has the following features:
 - 1 **Cursor:** A white cursor appears in the center of the screen in place of the reticle.
 - 2 **X:** Select to move the cursor horizontally.
 - 3 **Y:** Select to move the cursor vertically.

- 4 **Laser Rangefinder:** CONT (continuous rangefinding mode) and the rangefinding measurement appear in the upper-right corner of the screen.

NOTE: Use the edge of a building as a reference point to calibrate the laser.

5. Select the axis (X or Y) along which to move the cursor:
 - a. Short press the **Menu** **[M]** **Button** to toggle between X and Y. The selected axis is indicated by a blue arrow and blue font. X is selected by default.
6. Move the cursor along the selected axis:
 - a. Use the **Up** **[Q]** **Button** to move in the positive direction: X= Right and Y= Up.
 - b. Use the **Down** **[K]** **Button** to move in the negative direction: X= Left and Y= Down.
 - c. Short press the **Up** **[Q]** or **Down** **[K]** **Button** to move the cursor in the corresponding direction by 1 pixel; long press to move 10 pixels.
7. Short press the **Power** **[P]** **Button** to exit the laser rangefinder calibration interface without saving.
8. Long press the **Menu** **[M]** **Button** to save and exit to the home screen.

Pixel Defect Correction

Select and correct defective pixels

Defective pixels are pixels that do not change correctly compared to the other image pixels—they are either brighter or darker than surrounding pixels. The rifle scope has a tool which corrects any defective pixels on the sensor using its internal software.

1. Long press the **Menu** **[M]** **Button** to enter the main menu.
2. Short press the **Up** **[Q]** or **Down** **[K]** **Button** to move through the menu to select the pixel defect correction  menu item.



3. Short press the **Menu**  **Button** to enter the defective pixel correction interface.

4. The pixel correction interface has the following features:

1 Cursor: Cursor appears in the center of the screen in place of the reticle. Move the cursor to the position of the defective pixel.

2 X: Select to move the cursor horizontally.

3 Y: Select to move the cursor vertically

4 PIP Window: The Picture in Picture window appears in the lower-left corner.





5  00: Shows the number of defective pixels in the “to be corrected” list.



5. Select the axis (X or Y) along which to move the cursor:



a. Short press the **Menu**  **Button** to toggle between X and Y. The selected axis is indicated by a blue arrow and blue font. X is selected by default.

6. Move the cursor along the selected axis to the location of the defective pixel:

- Use the **Up**  **Button** to move in the positive direction: X= Right and Y= Up.
- Use the **Down**  **Button** to move in the negative direction: X= Left and Y= Down.
- Short press the **Up**  or **Down**  **Button** to move the cursor in the corresponding direction by 1 pixel; long press to move 10 pixels.

7. Repeat steps 5–6 to move the cursor along the second axis.

8. With the cursor in position, short press the **Power**  **Button** to add the defective pixel to the “to be corrected list.”

- Add** will briefly appear in the bottom-right corner of the PIP window.
-  00 will change to  01 to indicate that one pixel has been added to the correction list.

9. If the defective pixel has been added in error, short press the **Power**  **Button** a second time from the same X/Y coordinates (do not move the cursor) to remove the pixel from the “to be corrected list.” **Del** will briefly appear in the PIP window.

10. Repeat steps 5–9 to add additional defective pixels, if needed.

11. When all defective pixels have been added to the list, long press the **Menu**  **Button** to confirm changes.

12. A popup window shows the message “Do you want to keep these settings?” and two options, Yes and No. Yes is selected by default.



13. Short press the **Menu**  **Button** to select **Yes** to correct the list of defective pixels and exit to the home screen; **OR**





a. A 5-second countdown appears on the screen, followed by “Saved Successfully” and the device returns to the home screen.

14. Short press the **Up**  or **Down**  **Button** to select **No** to exit to the main menu without correcting any defective pixels.

NOTE: The PIP window and interface controls will move to the upper-left corner of the screen when cursor moves into the lower-left corner.

Compass Calibration





Calibrate the digital compass

1. Long press the **Menu**  **Button** to enter the main menu.
2. Short press the **Up**  or **Down**  **Button** to move through the menu to select the compass calibration  menu item.
3. Short press the **Menu**  **Button** to begin compass calibration.
4. A triaxial coordinate icon prompt will appear on the screen.
5. Follow the icon prompt to rotate the rifle scope at least 360 degrees along each axis, X, Y, and Z. Rotations must be completed within the 40-second calibration time.
6. After 40 seconds, the calibration is finished and the rifle scope will automatically exit to the home screen.



Settings









Adjust the general settings

1. Long press the **Menu**  **Button** to enter the main menu.
2. Short press the **Up**  or **Down**  **Button** to move through the menu to select the settings  menu item.
3. Short press the **Menu**  **Button** to enter the settings submenu.
4. There are seven submenu items: date, time, languages, units of measure, status bar, factory reset, and info.



SETTINGS MENU > DATE









Set the date

1. In the settings submenu, short press the **Up**  or **Down**  **Button** to select the date  menu item.
2. Short press the **Menu**  **Button** to edit the date. Blue triangle icons will appear above and below the selected date value. The year value is selected by default. The date is displayed in YYYY.MM.DD format.
3. Short press the **Up**  or **Down**  **Button** to select the correct value for each digit (year, month, and day).
4. Short press the **Menu**  **Button** to switch between digits. The two triangle icons indicate the selected digit.
5. Long press the **Menu**  **Button** to save the date and return to the home screen.



SETTINGS MENU > TIME







Set the time

1. In the settings submenu, short press the **Up**  or **Down**  **Button** to select the time  menu item.
2. Short press the **Menu**  **Button** to edit the time. Blue triangle icons will appear above and below the selected time value. The hour value is selected by default. The time is displayed in HH.MM, in 24-hour format.
3. Short press the **Up**  or **Down**  **Button** to select the correct value for each digit (hour and minute).
4. Short press the **Menu**  **Button** to switch between digits. The two triangle icons indicate the selected digit.
5. Long press the **Menu**  **Button** to save the time and return to the home screen.
6. The time appears on the right side of the status bar.



SETTINGS MENU > LANGUAGES







Select the language

1. In the settings submenu, short press the **Up**  or **Down**  **Button** to select the languages  menu item.
2. Short press the **Menu**  **Button** to enter the languages submenu.
3. Short press the **Up**  or **Down**  **Button** to move through the language options, English and Chinese. English is selected by default.
4. Long press the **Menu**  **Button** to confirm the selection and return to the home screen.



SETTINGS MENU > UNITS OF MEASURE

Set the units of measurement

1. In the settings submenu, short press the **Up**  or **Down**  **Button** to select the units of measure  menu item.
2. Short press the **Menu**  **Button** to enter the units of measure submenu.
3. Short press the **Up**  or **Down**  **Button** to move through units of measure options, meters and yards. Meters is selected by default.
4. The selected units of measure, m (meters) or y (yards), will display, along with the selected zero profile and distance, on the left side of the status bar.
5. Long press the **Menu**  **Button** to confirm the selection and return to the home screen.









SETTINGS MENU > STATUS BAR

Set the status bar to always show or to auto-hide.

This function enables automatic hiding of all interface information, aside from the reticle, for unobstructed image-view.

When auto-hide is turned on, after 8 seconds of inactivity the status bar, digital compass, and all interface icons will be automatically hidden. Shortcut buttons and the menu are disabled until the entire interface is again displayed. Press any button to show all interface information again.





NOTE: When auto-hide is on, the main menu, when open, will hide after 15 seconds of inactivity and the rest of the rifle scope interface will hide after an additional 8 seconds.

1. In the settings submenu, short press the **Up**  or **Down**  **Button** to select the status bar  menu item.
2. Short press the **Menu**  **Button** to enter the status bar submenu.
3. Short press the **Up**  or **Down**  **Button** to move through status bar options, show and hide. Show is selected by default.
4. Long press the **Menu**  **Button** to confirm the selection and return to the home screen.



SETTINGS MENU > FACTORY RESET

Restore factory default settings

1. In the settings submenu, short press the **Up**  or **Down**  **Button** to select the factory reset  menu item.
2. Short press the **Menu**  **Button** to enter the factory reset submenu.
3. Two options, Yes and No, appear; Yes will restore factory settings and No will cancel the operation. No is selected by default.



- Short press the **Menu** **[M]** **Button** to confirm cancellation of the factory reset and return to the submenu; **OR**
- Short press the **Up** **[Q]** or **Down** **[K]** **Button** to select **Yes** and short press the **Menu** **[M]** **Button** to confirm the factory reset. Factory settings will be restored and the rifle scope will reboot automatically

NOTES:

- A factory reset cannot be undone.
- The settings listed below will be reset to the factory defaults:
 - Imaging mode: White Hot
 - Display Brightness: 3
 - Image Sharpness: 3
 - Magnification: 2x
 - Ultra-clear Mode: Off
 - Wi-Fi: Off
 - Video Output: Off
 - Calibration: Automatic
 - Digital Compass: Off
 - Gravity Sensor: Off
 - Zeroing Profile: A
 - Reticle Type: 1
 - Reticle Color: Black
 - Microphone: Off
 - Standby: Off
 - Languages: English
 - Status Bar: Show
 - Wi-Fi SSID: Geni_XXXXXX_XXXXXX or GENI_XXXXXX
 - Wi-Fi Password: 12345678

SETTINGS MENU > INFO ⓘ

Show device information

- In the settings submenu, short press the **Up** **[Q]** or **Down** **[K]** **Button** to select the info ⓘ menu item.
- Short press the **Menu** **[M]** **Button** to enter the info submenu.
- The info submenu will display the following information about the rifle scope: the product model, GUI version, SYS Info, boot version, FPGA, PN and SN number of the rifle scope, and hardware version.
- Long press the **Menu** **[M]** **Button** to save and return to the home screen.



22. BASIC INSPECTION

It is recommended to carry out a technical inspection before each use. Please check the following:

- The rifle scope appearance: there should be no cracks in the body, or visible damage.
- The condition of the objective lens and eyepiece: there should be no cracks, greasy spots, dirt or other deposits on the lens.
- The internal rechargeable battery should be fully charged.
- The control buttons should be in working order.

23. BASIC MAINTENANCE

Always replace the objective lens cap **(1)** after use to avoid damaging or scratching the lens. Never touch the lens directly; oil from your skin can damage the lens coating and surface.

Basic maintenance should be carried out at least twice a year and includes the following steps:

- Wipe the surface of external metal and plastic components with a clean, dry cotton cloth. Do not use chemical, corrosive, or abrasive cleaners. Canned air may also be used to clean the external components.
- Clean the electric contacts and battery slots on the rifle scope using a non-greasy organic solvent.
- Check the lens and eyepiece. If necessary, remove any dirt or sand from the optics; a non-contact cleaning method is preferred.
- Cleaning the exterior of the lens should only be done with the included microfiber lens cloth or similar product. Only clean the lens when it is visibly soiled. Frequent wiping or cleaning can degrade the anti-reflective lens coating.

24. WARRANTY

At iRayUSA we're first and foremost hunters and users of our products and we understand that failure isn't an option. We also understand that having to wait extended periods for repair isn't something that a customer should have to put up with when something does go wrong. During your published warranty period, iRayUSA will repair or replace, at its discretion, any optic that becomes defective during normal use. Additionally, if we cannot fix your optic in less than one week, we will offer to replace it with a replacement product in like or better condition. If you would rather wait for your specific optic to be repaired, we can handle that too.

We know you've never seen this from a thermal manufacturer, neither have we, and that's why we started iRayUSA.

Our warranty follows the product, and is not tied to the original owner. The warranty period is tied to the date of sale to the dealer. This warranty only covers normal use and does not cover cosmetic damage, normal wear, intentional damage, theft, loss, any act of God, or a condition caused by use other than intended. Any product that is modified, opened, or tampered with will void any warranty coverage. Any serial number damage or alteration on the product will be considered modification. Be sure to register your RICO G Family rifle scope at irayusa.com/register.

To return a product for repair:

1. Go to irayusa.com/warranty and click the **Request an RMA button** to request an RMA number. Returns will not be accepted without an RMA.
2. The customer is responsible for shipping the product to iRayUSA, to the address below. iRayUSA will return the product at no cost.

iRayUSA
800 Railhead Road #316
Fort Worth, TX 76106

- The one-week timeline starts from the time of receipt of product at iRayUSA.
- iRayUSA is not liable for any damages or loss incurred when shipping to iRayUSA.
- This warranty gives you specific legal rights, and you may also have other rights which vary from state to state.

Please give us a call at **800-769-7125**, visit irayusa.com/warranty, or email info@irayusa.com with any questions.

25. FCC STATEMENT

FCC ID: 2AYGT-2H1

This device complies with part 15 of the FCC Rules. Operation is subject to the following two conditions: (1) this device may not cause harmful interference, and (2) this device must accept any interference received, including interference that may cause undesired operation.

NOTE: Changes or modifications not expressly approved by iRayUSA could void the user's authority to operate the equipment.

NOTE: This equipment has been tested and found to comply with the limits for a Class B digital device, pursuant to part 15 of the FCC Rules. These limits are designed to provide reasonable protection against harmful interference in a residential installation. This equipment generates, uses and can radiate radio frequency energy and, if not installed and used in accordance with the instructions, may cause harmful interference to radio communications. However, there is no guarantee that interference will not occur in a particular installation. If this equipment does cause harmful interference to radio or television reception, which can be determined by turning the equipment off and on, the user is encouraged to try to correct the interference by one or more of the following measures:

- Reorient or relocate the receiving antenna.
- Increase the separation between the equipment and receiver.
- Connect the equipment into an outlet on a circuit different from that to which the receiver is connected.
- Consult the dealer or an experienced radio/TV technician for help.

This device was tested for typical body-supported operations and use. To comply with RF exposure requirements, a minimum separation distance of 0.5cm must be maintained between the user's body and the handset, including the antenna. Third-party belt-clips, holsters, and similar accessories used by this device should not contain any metallic components. Body accessories that do not meet these requirements may not comply with RF exposure requirements and should be avoided. Use only the supplied or an approved antenna.

26. GENERAL TROUBLESHOOTING

The troubleshooting table on the next page lists issues that may occur when operating the rifle scope. Carry out the recommended troubleshooting steps in the order shown in the table. Please contact iRayUSA at 800-769-7125 or irayusa.com/support or an authorized vendor for assistance before attempting to perform any modifications or repairs beyond the scope of the troubleshooting procedures in this manual. Unauthorized repairs or modifications will void your warranty.

| ISSUE | POSSIBLE CAUSES |
|--|--|
| The rifle scope will not turn on. | The battery is very low or has completely discharged. |
| The rifle scope can not connect to a computer or external power supply. | External power supply has completely discharged. |
| | Computer is turned off. |
| | Data cable is damaged. |
| The rifle scope can not connect to the mobile device (smartphone or tablet). | Wi-Fi is not turned on. |
| | Wrong Wi-Fi password entered. |
| | Too many Wi-Fi signals near the rifle scope. |
| Wi-Fi signal is lost or interrupted. | Smartphone or tablet is out of range of a strong Wi-Fi signal, or there are obstacles between the rifle scope and the mobile device. |
| The image is fuzzy, not clear, not balanced, with artifacts. | Non-uniformity correction is required. |
| The image is too dark. | Display brightness level is too low. |
| The GUI is clear, but the image is fuzzy. | The lens is not focused. |
| | There is dust on the interior or exterior optical surfaces of the lens. |
| | There is condensation on the interior or exterior optical surfaces of the lens. |
| The aiming reticle shifts after firing rounds. | The rifle scope is not mounted securely or the mount is not secured on the rifle scope. |

| TROUBLESHOOTING STEPS |
|--|
| Charge the battery. |
| Check the external power supply and charge it if necessary. |
| Power on the computer. |
| Replace the data cable. |
| Turn on the Wi-Fi in the main menu. See Main Menu > Wi-Fi on page 40. |
| On the mobile device, go to Settings > Wi-Fi and enter the correct password. The default password is 12345678. See Main Menu > Wi-Fi on page 40. |
| Move the rifle scope and mobile device to an area with no or fewer Wi-Fi signals. |
| <ul style="list-style-type: none"> • Try again when Wi-Fi signal is stable. • Relocate the rifle scope closer to the Wi-Fi signal. |
| Perform a non-uniformity correction. See Non-uniformity Correction on page 28 and Main Menu > Calibration on page 41. |
| Adjust the display brightness in the quick menu. See Using the Quick Menu on page 25. |
| <ul style="list-style-type: none"> • Adjust the focus on the target by rotating the objective lens focus knob/ring (2) • Adjust the image sharpness in the quick menu. See Using the Quick Menu on page 25. |
| <ul style="list-style-type: none"> • Wipe the outside optical surfaces with the included microfiber lens cloth. |
| <ul style="list-style-type: none"> • Wipe the outside optical surfaces with the included microfiber lens cloth. • Allow the rifle scope to dry by leaving it in a warm, dry environment for at least 4 hours. |
| <ul style="list-style-type: none"> • Check that the rifle scope has been securely mounted. • Make sure you are using the same brand, type, and weight of bullets as when the rifle scope and weapon were initially zeroed. • If the rifle scope was zeroed in different environmental conditions, a slight shift of the zero is possible. |

| ISSUE | POSSIBLE CAUSES |
|--|---|
| The image of the object being observed is missing. | Looking through glass. |
| The rifle scope will not focus. | Image settings are not optimal for the current environmental conditions or the object being observed. |
| Image quality is too low or the detection range is reduced. | These issues may occur due to the weather conditions, such as snow, rain, humidity, and fog. |
| When the rifle scope is used in low temperature conditions, the image quality of the surroundings is worse than in warm temperature conditions. | Environmental conditions. |

27. NOTES

| TROUBLESHOOTING STEPS |
|--|
| Remove any glass windows from the field of view. |
| <ul style="list-style-type: none"> • Check the outer surfaces of the objective lenses and eyepiece and, where necessary, wipe away any dust, condensation, frost, etc. • In cold weather, you can use special anti-fogging coatings, such as those made as for corrective glasses. • Adjust the focus on the target by rotating the objective lens focus knob/ring (2). • Adjust the image sharpness in the quick menu. See Using the Quick Menu on page 25. • Adjust the image and device settings. See Quick Start Guide on page 18. • Turn on Ultra-clear mode. See Main Menu > Ultra-clear on page 39. |
| Turn on Ultra-clear mode. See Main Menu > Ultra-clear on page 39. |
| In warm temperature conditions, objects being observed (surroundings and background) heat up differently because of thermal conductivity, thereby generating a high temperature contrast. Accordingly, image quality produced by the rifle scope will be higher. In low temperature conditions, the background will cool down to roughly the same temperature, and thus the temperature contrast is substantially reduced and image detail can go down as there is less contrast in the scene. This is a normal function of a thermal imager and is no indicator of actual detector performance. |



**800 Railhead Road #316
Fort Worth TX 76106
800-769-7125
682-499-0047
info@irayusa.com**